



Operations Manual

**TBC•SYNC+**

**Digital Video Time Base Corrector  
and Synchronizer**

with or without  
Digital Effects

The information in this manual is furnished solely for the purpose of providing instructions for installation and operation of the equipment described herein. Any other use of this information without the written consent of Prime Image, inc. is strictly prohibited.

**PRIME IMAGE, inc.**

**3 YEAR LIMITED WARRANTY**

For a period of 3 years from the date of original purchase (the "Limited Warranty Period"), Prime Image, inc. ("Company") will, at Company's option, either replace, repair, or refund the original purchase price paid by the distributor for, any defective product manufactured by Company and sold by its authorized distributor in the U.S. and Canada ("Product") to the person making a claim under this Limited Warranty, provided the Original purchaser complies with the terms and conditions set forth in this document.

**To Whom Does This Limited Warranty Apply?**

This Limited Warranty applies only to a person or company that returns a completed warranty card to company within thirty (30) days of purchase of the Product and demonstrates to Company's reasonable satisfaction he or it was the original purchaser of a Product purchased in new condition in the original package from an authorized distributor of Company in the U.S. or Canada. This Limited Warranty is not transferable or assignable.

**What Is Covered?**

If a claim is made within the Limited Warranty Period by the original purchaser, Company will repair or replace a Product which, in Company's reasonable judgment after inspection, is defective in either workmanship or materials. Alternatively, Company may refund the original purchase price paid by the distributor of the Product. Whether Company will repair, replace, or refund the original purchase price paid by the distributor is up to the Company.

**What Is Not Covered?**

Company's liability is limited to repair, replacement or refund of the original purchase price paid by the distributor. Company will not be responsible for consequential or incidental damages or expenses of any kind or nature, regardless of the cause, even if Company has any knowledge regarding the probability of their occurrence. Without limiting the generality of the statement, Company will not be liable for injury to persons or property, loss of use of the Product, lost goodwill, lost profits, work stoppage, impairment of or damage to other goods. If any of the following have occurred, it will void this Limited Warranty, and Company will have no liability of any kind to the owner:

1. The Product shows evidence it has been tampered with, or that it has been subject to misuse, abuse or negligent use;
2. Any repair or alteration of the Product was made by someone other than Company, including the distributor, except with Company's written authorization;
3. The Product was either improperly installed, operated or used for a purpose for which it was not intended;
4. The owner failed to provide normal maintenance, if any is required, in accordance with Company's instruction manual; or
5. The serial numbers or other factory-installed labeling has been altered or removed.

**How Should A Claim Be Made?**

The original purchaser should return the defective Product to Company at the address set forth below, together with proof of purchase, packed with either the original packaging or other similar packaging designed to avoid damage to the Product during the course of shipment:

Prime Image, inc.  
1995 Las Plumas Avenue  
San Jose, CA 95133

If this Limited Warranty applies, Company will reimburse the owner for the cost of shipment to Company and will pay for the cost of return shipment; provided, however, Company shall be obligated to ship and pay only for deliveries that are made by Federal Express standard overnight service within the continental U.S.

**Is This The Only Warranty?**

THIS LIMITED WARRANTY IS GIVEN IN LIEU OF ALL OTHER WARRANTIES, WHETHER EXPRESS OR IMPLIED. THERE ARE NO WARRANTIES AS TO THE FITNESS OF THE PRODUCT FOR ANY PARTICULAR PURPOSE. COMPANY DISCLAIMS ANY OTHER WARRANTY, EXPRESS OR IMPLIED, THAT PRODUCTS ARE MERCHANTABILITY.

This limited Warranty gives you specific legal rights, and you may also have other rights which may vary from state to state or province to province.

# Table of Contents

<b>Section 1</b>	
<b>General Information</b> .....	5
Scope of this Manual .....	5
Manual Improvements .....	5
Proprietary Information .....	5
<b>Section 1.1 Product Description</b> .....	5
Features .....	5
Posterization .....	6
Sepia .....	6
Mosaic .....	6
Function .....	6
Drop-Out Corrector .....	7
Video Synchronizer .....	7
<b>Section 1.2 Applications</b> .....	8
<b>Section 1.3 Specifications</b> .....	9
Performance .....	9
Environmental .....	9
<b>Section 2</b>	
<b>Shipping</b> .....	10
Section 2.1 Unpacking .....	10
Section 2.2 Inspection .....	10
Section 2.3 Accessories .....	11
Section 2.4 Packing .....	11
<b>Section 3</b>	
<b>Installation</b> .....	12
Section 3.1 Power and Environmental Requirements .....	12
Section 3.2 Mechanical Installation .....	12
Section 3.3 System Interconnection .....	13
<b>Section 4</b>	
<b>Operation</b> .....	14
Section 4.1 Controls and Indicators .....	14
Section 4.2 First Time Operation .....	15
Section 4.3 Operating Modes .....	16
Power OFF .....	16
Power ON .....	16
Normal Color, Genloc .....	17

Section 4.4 Synchronization .....	17
Defining Bad Field .....	18
Horizontal Line Detect .....	18
Missing Vertical Sync .....	18
Incorrect Vertical Sync .....	18
Tape Head Switch Mask .....	18
De-activating Auto Freeze (A Fr) Functions .....	18
Section 5	
Alignment .....	19
Section 5.1 Installation Adjustment .....	19
Section 6	
Servicing .....	22
Routine Maintenance .....	22
Unit Malfunction .....	22
Service Calls .....	22
Section 6.1 Troubleshooting .....	23

### List of Illustrations

Figure	Subject	Page
1-1.	Example of Interconnection .....	8
3-1.	Rear Panel Connectors .....	13
4-1.	Front Panel Controls and Indicators .....	15
5-1.	Internal Adjustment Location .....	21

### List of Tables

Table	Subject	Page
2-1.	List of Accessories .....	11
3-1.	Interconnection Requirements .....	13
4-1.	Front Panel Controls and Indicators .....	14
5-1.	Internal Preset Controls .....	19
6-1.	Troubleshooting .....	23

# Section 1

## General Information

---

### Scope of this Manual

This manual gives you the information necessary to install, operate, and perform routine maintenance on the Model TBC·SYNC+ Digital Video Time Base Corrector and Synchronizer, manufactured by Prime Image, inc.

### Manual Improvements

Changes to this manual are documented by numbered engineering change orders. Individual users of this manual are encouraged to report any errors, omissions, or suggestions for improvement to the following address:

Publications Department  
Prime Image, inc.  
19943 Via Escuela  
Saratoga, CA 95070

### Proprietary Information

The information in this manual is furnished solely for the purpose of providing instructions for installation and operation of the equipment described herein. Any other use of this information without the written consent of Prime Image, inc. is strictly prohibited.

## Section 1.1 Product Description

---

This section describes the features and function of the TBC·SYNC+ System.

### Features

The TBC·SYNC+ System is a high performance digital video time base corrector (TBC) with advanced video tape production capabilities for demanding professional requirements.

The TBC·SYNC+ contains a full complement of processing functions using a component video format internally. The System has the features and operating modes customarily provided in high quality TBCs including compatibility with dynamic tracking VCRs, 3.58 feedback, and Drop-Out Corrector (DOC). The TBC·SYNC+ model also features a video synchronizer for freeze frame capabilities. Video "special effect" features enhance the usefulness of the TBC·SYNC+ System:

**Posterization**

Output video is quantized into discrete levels, producing a coarse grained or contoured effect. Quantization severity, controlled by the clockwise rotation of the control, affects the luminance. To activate this feature, pull out the posterization knob.

**Sepia**

Output is converted from a full color image to a brown-toned representation. To activate this feature, pull out the sepia knob.

**Mosaic**

Output is quantized spatially in rectangular pattern with an adjustable block size. To activate this feature, pull out the mosaic knob.

These special effect functions may be used separately or may be combined to produce a wide range of effects that enhance the visual interest of a sequence or still.

In addition to improving the time base stability of the video playback, the TBC·SYNC+ provides a convenient means for correcting other parameters of the video that may be incorrect. Front panel controls allow adjustment of Video level, Set-up level, Chroma level, Hue, Strobe and Freeze. These parameters may be changed by pulling out the appropriate knob and rotating to the desired level. For a description of Strobe and Freeze adjustments, see the section "Video Synchronizer" on page 7.

**Function**

The TBC·SYNC+ Digital Video Time Base Corrector and Synchronizer is used to correct the timing of a signal from a video tape recorder to the level of stability required for broadcast or for clean editing. The TBC·SYNC+ provides timing correction by digitizing the video, storing up to 525 horizontal lines worth of information, and recalling the stored data at a stable rate.

Before digitization, the input video is separated into its luma and chroma components. Digitization to 8-bit precision allows 1 part in 256 or .4 IRE maximum resolution in luma and .4% maximum of chroma saturation. The digitization process occurs at greater than 8 MHz for luma and at greater than 4 MHz for chroma. This speed allows retention of the spectral components in the picture below the chrominance information as well as excellent color performance.

After recall from the RAM memory, the digital video is reconverted to analog components and recombined with clean sync, blanking, and burst from the sync generator to form a composite video signal.

The TBC·SYNC+ contains an internal sync generator that may be used as the reference sync or may in turn be "genlocked" to an external reference.

## Drop-Out Corrector

The TBC·SYNC+ provides Drop-Out Corrector (DOC) by monitoring the RF from the recorder. When a drop-out is detected, the memory data is flagged as being of questionable quality and is replaced with video recorded from the previous line.

## Video Synchronizer

The original full-frame video synchronizer was developed for use at E.N.G. and Sports events. Its purpose was to synchronize a non-synchronous signal, typically microwave transmitted, to a reference signal or to another non-synchronous signal.

The characteristics of a full-frame video synchronizer mandated full-frame (525-line) memory capabilities. Once the synchronizer was developed, it quickly made its way from the "on location" broadcasting vans into post-production houses. There it became a handy tool for freeze frame/freeze field applications and a way to synchronize two non-V-locked VCRs.

Through advanced technology Prime Image, inc. has developed a video synchronizer that gives you clean "hot switching" and reliable operation when coming out of an "auto freeze." In addition to improved hot switching, the TBC·SYNC+ allows you to freeze frame, freeze field "1," or freeze field "2." It also includes a variable field strobe and frame strobe mode. All of these features will work concurrently with the special effect controls.

- |                       |   |
|-----------------------|---|
| <i>Freeze Frame</i>   | Full frame memory lets you freeze a desired frame. Once a frame of memory is stored in RAM, Field "1" or Field "2" may be chosen.       |
| <i>Freeze Field 1</i> | In an action shot, if the output video is jittery due to Field 1 vs. Field 2 differences, it may be necessary to select a field freeze. |
| <i>Freeze Field 2</i> | Select Field 1 or Field 2.  |
| <i>Frame Strobe</i>   | Strobes output video one frame at a time. Frame strobe rates are adjustable by using the strobe pot on the front panel.                 |
| <i>Field Strobe</i>   | Strobes output video one field at a time. Field strobe rates are adjustable by using the strobe pot on the front panel.                 |

All of the above functions are activated by pulling out on the strobe potentiometer (pot).



## Section 1.2 Applications

The TBC·SYNC+ is intended to be used with a V-locked or non-V-locked VCR, microwave, off air, or other non-synchronous feed. It operates on the video to stabilize the timing and provide both horizontal and color lock to the reference sync signal. The output may be switched or mixed with other sources. Figure 1-1 depicts a typical system using the TBC·SYNC+.

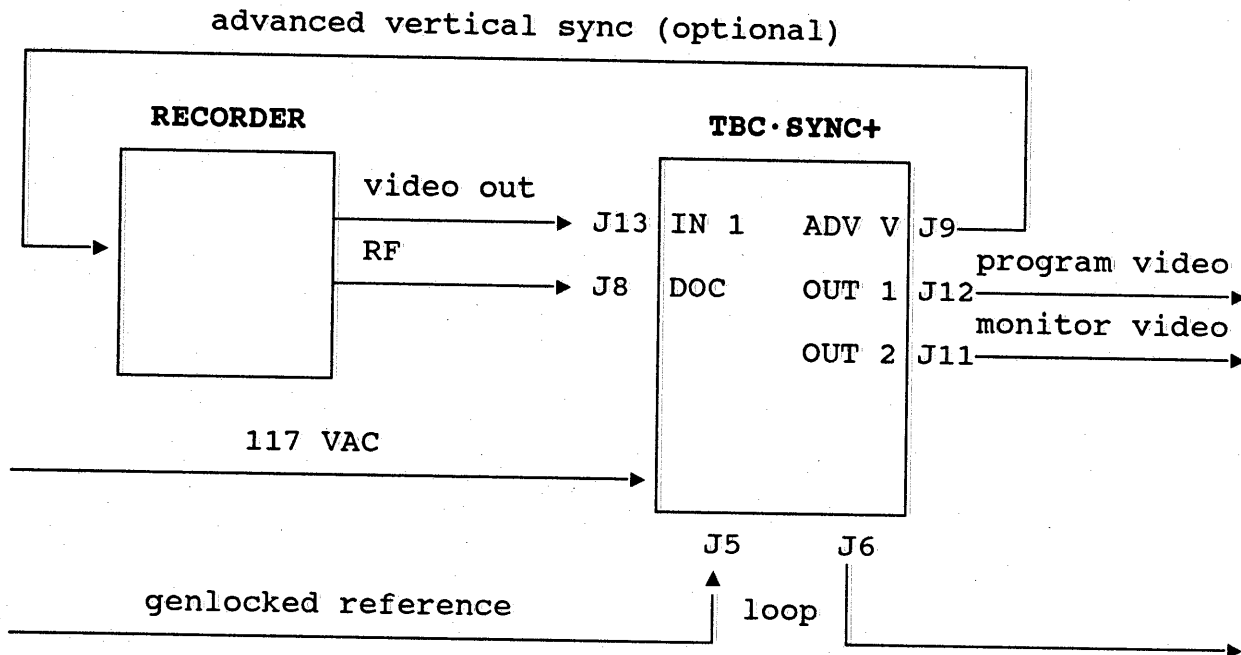

Figure 1-1. Example of Interconnection

The TBC·SYNC+ is designed to operate with NTSC type 525-line synchronous or non-synchronous signals.

## Section 1.3 Specifications

---

The following specifications apply at 20°C:

### Performance

Window	525 + 16 horizontal lines
Bandwidth	4.2 MHz
Signal-to-Noise Ratio	58 dB
Differential Phase	1.5°
Differential Gain	1.5%
K-Factor	3%
Sampling	8-bit luma, 8-bit chroma
Residual Time Base Error	±15 ns.

### Environmental

Operating Temperature	+32° to +113°F (0° to +45°C)	
Operating Humidity	10% to 95% RH, non-condensing	
Power Supply	117 VAC ±10%, 50-60 Hz	
Power Dissipation	60 VA	
Width	19"	(48.3 cm)
Height	1.75"	(4.45 cm)
Depth	15"	(38.1 cm)
Weight	16 lbs.	(7.3 kg)

## **Section 2 Shipping**

---

This section contains the information necessary for you to unpack, inspect, repack and ship the TBC·SYNC+ System.

### **Section 2.1 Unpacking**

---

The TBC·SYNC+ is shipped, fully assembled, in a re-usable cardboard shipping carton which may be opened with a sharp, short-blade knife. Within the carton the TBC·SYNC+ is supported in foam packing material and wrapped in a poly bag. Accessories are contained in a separate bag below the unit. An external pouch contains a packing list delineating the contents of the carton. The shipping weight of the TBC·SYNC+ with carton is less than 30 lbs. and may be carried with care by one person.

### **Section 2.2 Inspection**

---

The individual parts of your unit were inspected prior to shipment, and the unit should be in good operating order. Carefully inspect the unit and accessories for any physical damage sustained in transit. If the unit is received in a damaged condition, notify your dealer or the factory immediately, and file a claim with the carrier.

Please verify that you have received all the items that should accompany the unit. Refer to the accessory parts list in Section 2.3. If you have any difficulties with the unit, if it is not operating properly, or if accessories are missing, contact your dealer or the factory Customer Service Department.

Retain the carton and original packing materials in case the unit must be shipped.

## Section 2.3 Accessories

---

The following table lists the accessories you should have received with your TBC•SYNC+ System:

*Table 2-1. List of Accessories*

Description	Quantity
Line cord, AC power	1
TBC•SYNC+ Operators Manual	1
Packing carton with spacers and bag	1

## Section 2.4 Packing

---

When repacking the unit for shipping, be sure that the unit and accessories are secured in the configuration described in Section 2.1. Check that all seams are securely sealed with tape, and the carton is clearly marked.

## Section 3 Installation

---

This section gives you the information necessary to properly install the TBC·SYNC+ System including power, environmental, mounting, and interconnection requirements.

### Section 3.1 Power and Environmental Requirements

---

The TBC·SYNC+ System is designed to operate from a power source providing 117 VAC, single phase 60 Hz power, at 60 VA. The unit is protected by a 1 Amp fuse.

To protect operating personnel and equipment, the unit should only be connected to a three-pronged grounded receptacle using the power cable provided. See Figure 3-1 for the location of the power cable connector and the main power switch.

The TBC·SYNC+ is cooled by an internal fan that draws cool external air in through the slots at the top of the front panel and exhausts warmed air out the rear panel, if unobstructed. When installing the TBC·SYNC+, leave a minimum of 6 inches clearance behind the unit to provide maximum air flow for cooling.

#### **Warning**

Proper operation of the unit within the specifications cannot be guaranteed if the top cover of the unit is removed thus depriving the electronics of optimum cooling. Furthermore, operating the unit with the top removed will expose the operator to the fan blades which are not shrouded. This practice is NOT recommended.

### Section 3.2 Mechanical Installation

---

The TBC·SYNC+ is shipped ready for bench-top operation with four rubber feet on the case bottom. If rack mounting is desired, the unit may be mounted directly to the rack by screws through the mounting ears. If a unit is mounted directly below the TBC·SYNC+, remove the feet from the TBC·SYNC+ case bottom to allow sufficient vertical clearance.

## Section 3.3 System Interconnection

All connections to the TBC•SYNC+ System are made at the rear panel. The following table describes the interconnection requirements.

Table 3-1. Interconnection Requirements

Ref	Name	Characteristics	Function
	AC Power	117 VAC, 60 Hz, 50 VA	
J13	Video In	1Vpp, 75 ohm, BNC	Uncorrected video output
J5/J6	Genloc In	HiZ loop-thru, 2 BNCs	Reference sync input from external generator. Video Outputs 1 & 2 will be locked to this input.
J8	DOC In	RF 100 mV min, BNC	
J10	TBC-V	Comp sync, 300 mV min, BNC	Uncorrected sync input from dynamic tracking VCR
J12	Video Out 1	1Vpp, 75 ohm, BNC	Primary corrected video output. May be bypassed using front panel "Bypass" switch.
J11	Video Out 2	1Vpp, 75 ohm, BNC	Secondary video output
J9	Adv Sync Out	1Vpp, 75 ohm, BNC	Vertical sync with advanced timing to recorder
J7	3.58 Feedback	1Vpp, 75 ohm, BNC	

Figure 3-1 shows locations of the rear panel connectors.

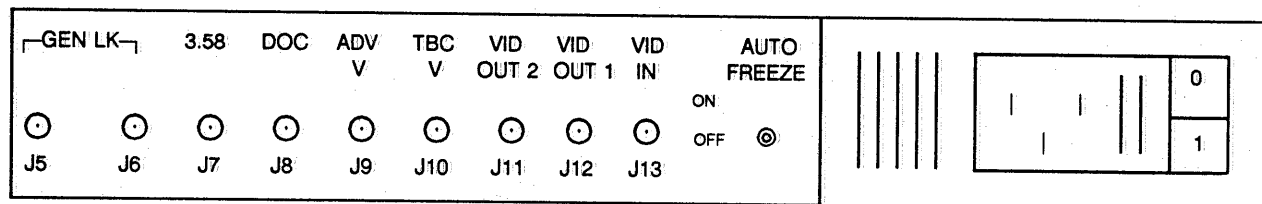

Figure 3-1. Rear Panel Connectors

The unit may be connected to your system according to the desired application using RG-59/U (or equivalent) coaxial cable terminated with BNC connectors. For first time operation, see Section 4.2. For installation adjustments, see Section 5.1.

## Section 4 Operation

This section provides the information necessary to operate the TBC•SYNC+. It includes descriptions of the operating controls and indicators, instructions for first-time operation, and descriptions of the operating modes.

### Section 4.1 Controls and Indicators

The following table describes the characteristics and functions of front panel controls and indicators. For descriptions of internal preset adjustments, see Section 5.1.

*Table 4-1. Front Panel Controls and Indicators*

Ref	Name	Characteristics	Function
	Power Switch (ON/OFF)	2-position rear panel rocker	AC power
S1	Bypass Switch	2-position push-push	Bypasses Video In directly to Video Out 1
SR1	Video Level Control	±3 dB pot, push to preset, pull to adjust	Normalizes video input
SR2	Setup Level Control	±10 IRE pot, push to preset, pull to adjust	Normalizes video input
SR3	Chroma Level Control	+3 to -60 dB pot, push to preset, pull to adjust	Normalizes video input
SR4	Hue	±45° pot, push to preset, pull to adjust	Normalizes video input
J2 1-8	Video Level Indicator	7 LEDs (4 yellow, 1 green, 2 red)	Indicates input video level in bargraph format
J4	Genlock Indicator	LED (green)	Indicates presence of a Genlock reference input
SR5	Strobe	Pull on, push off	Activates Freeze/Strobe function
J3	Freeze	Select Freeze/Strobe mode	Selects Field/Frame/Strobe
SR6	Poster Control	Pull on, rotate CW to 1 magnitude, push off	
SR7	Sepia Control	Pull on, rotate CW to 1 magnitude, push off	
SR8	Mosaic Control	Pull on, rotate CW to 1 magnitude, push off	
R139	Horizontal Phase ( $H\phi$ )	±1 $\mu$ S, multiturn trimpot	Adjusts relative timing of the sync on the output video to the reference video
R140	Burst Phase ( $SC\phi$ )	>360°, multiturn trimpot	Adjusts relative timing of the burst on the output video to Genlock reference

Figure 4-1 shows locations of the front panel controls and indicators.

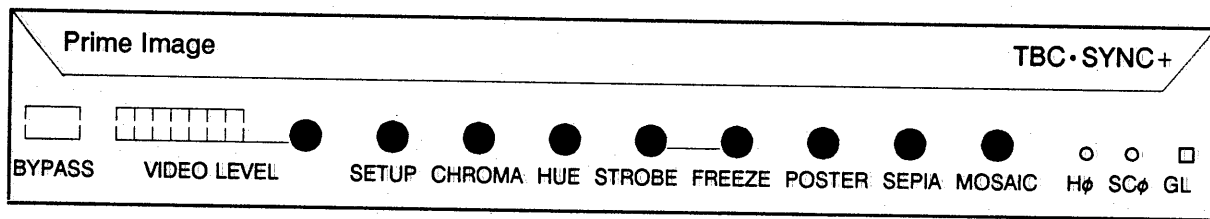

Figure 4-1. Front Panel Controls and Indicators

## Section 4.2 First Time Operation

The following procedures should be followed after installing the TBC·SYNC+ to ensure proper operation in your system environment. If proper operation cannot be obtained or if malfunction is suspected, refer to "Unit Malfunction" in Section 6.

### Note

Do NOT alter the settings of any internal switches or potentiometers. They have been preset at the factory and should be adjusted only by qualified service personnel.

1. Connect VIDEO OUT connector J12 to the following test equipment using 75 ohm coaxial cable:
  - NTSC standard 525 line/60 Hz picture monitor
  - NTSC vectorscope (Tek 520A or equivalent)
  - NTSC waveform monitor (Tek 529 or equivalent)
2. Activate system inputs to the TBC·SYNC+ from a recorder or a test signal generator at J13 and a reference generator at J5/J6, if desired.
3. Set AC power switch to ON, set the Bypass switch to ON, and verify the following:
  - a. The fan operates.
  - b. At least one video level indicator is ON.
  - c. If a Genloc reference is connected, J4 is ON.
  - d. A normal picture is displayed on the monitor.



4. Set the Bypass switch to OFF and verify the following:
  - a. A normal picture is displayed on the monitor (may be displaced vertically).
  - b. Each of the four video controls (Video level, Chroma level, Set-up level, and Hue: pull out to adjust, push in for preset) operate when activated; when all are returned to the preset condition, video output on the waveform monitor is normalized.
  - c. Each of the three video effect controls (Poster, Sepia, and Mosaic) operate when activated. Pull out to activate; push in to turn off.

In this configuration the operating specs may be verified except residual error.

5. Place the recorder in PLAY and verify the following:
  - a. The output video is time base corrected.
  - b. A properly framed picture is displayed on the monitor.

In this configuration the DOC and dynamic tracking capabilities of the TBC•SYNC+ may be demonstrated.

If the factory preset levels for the video controls are not proper or if you wish to adjust the systems timing for your installation, refer to Section 5.1.

### **Section 4.3 Operating Modes**

---

This section describes the settings for the various operating modes.

#### **Power OFF:**

In this mode the signal present at Video In connector J13 is directly connected to Video Out 1 connector J12.

#### **Power ON:**

In this mode the AC input is connected, the AC power switch is ON, and the Bypass switch S1 is ON.

The Video Out 1 connector J12 carries input video from J13, but the Video Output 2 connector J11 contains a corrected version of the input video.

In this mode at least one front panel indicator will be ON.

### **Normal Color, Genloc:**

In this mode AC switch is ON, the Bypass switch is OFF, and at least one indicator is lit.

In this mode all controls are active and the TBC·SYNC+ is correcting video.

Operation of the TBC·SYNC+ is fully automatic and will tolerate hot switches of the input with full correction established within one frame time.

In the normal operating mode, the TBC·SYNC+ may free-run on its internal sync generator or lock to an external reference input at connector J5/J6.

If a reference input is detected, the TBC·SYNC+ will phase-lock to signal, and the Genloc indicator J4 will be ON.

The output, when genlocked, is RS-170A compatible and factory-set to the correct sync-burst phase relationship.

The sync and burst phase may be adjusted manually using the front panel controls ( $H\phi$   $SC\phi$ ), if desired.

## **Section 4.4 Synchronization**

---

The TBC·SYNC+ receives a non-synchronous video signal via the "Video In" connector J13 on the rear panel. The video information is separated into its component format and then digitized. This non-synchronous information is written into RAM, one line at a time. Once a known good field (262½ lines) is stored in RAM, it is read out of RAM, constructed back into an analog signal, and outputted through the Video Out 1 and 2 jacks J12 and J11. Synchronization occurs because the read clock is generated, in part, by a voltage controlled oscillator (VCO) whose frequency is determined by use of an external Genloc source inputted to J5 or J6, or by use of an internal sync generator chip.

If a bad field is written into RAM, the TBC·SYNC+ will detect it and continue reading (outputting) the last known good field. This is known as an auto freeze. Once a good field is written into RAM, the TBC·SYNC+ de-activates itself from the auto freeze mode and begins the continuous read/write cycle until the next bad field occurs. Auto freeze may be de-activated by switching S3 to the OFF position.

## Defining Bad Field

The TBC·SYNC+ monitors the input video signal and auto freeze under four conditions:

**Horizontal Line Detect:** If the TBC·SYNC+ does not detect a horizontal sync pulse within lines of the last known good H. sync pulse, the TBC·SYNC+ will auto freeze. Loss of input video or excessive skewing are examples of how the H. sync detection circuitry will go into auto freeze mode.

**Missing Vertical Sync:** If a vertical sync pulse is missing during any field, the TBC·SYNC+ considers this a bad field and will auto freeze. As with the horizontal line detect circuitry, the loss of input video will activate the missing vertical sync detection circuitry and send the TBC·SYNC+ into an auto freeze mode.

**Incorrect Vertical Sync:** By definition, vertical sync occurs every 16.3 milliseconds, switching between even and odd fields. The TBC·SYNC+ monitors the incoming video signal and detects both the position (timing) of vertical sync as well as field identification (even/odd). A tape that has incorrectly edited video on it might contain a segment whose fields read even, odd, even, odd . . . The detection of the two repeating fields will cause an auto freeze.

**Tape Head Switch Mask:** Ten lines of video are masked during each field. This is done so that horizontal line detect circuitry does not auto freeze.

## De-activating Auto Freeze (A Fr) Functions

Your new TBC·SYNC+ has been set at the factory to auto freeze during any of the four previously mentioned conditions. It may be desirable to de-activate any one or all of the incorrect video detection circuits. This may be accomplished by following these instructions:

Remove the six screws that secure the top cover to the TBC·SYNC+. Inside you will see two Printed Circuit Boards (PCBs). The bottom PCB is the TBC. The top board is the synchronizer, on which you will notice a four-position DIP switch. To disable an auto freeze function, simply switch the desired switch to the OFF position.

S1	H. Line Detect	S3	Head Switch Mask
S2	Missing V Sync	S4	Incorrect V Sync

Once the desired changes have been made, re-secure the unit's top cover. Never operate the TBC·SYNC+ without a top cover for a prolonged period of time.

A master auto freeze (A Fr) disable switch is located on the rear of the TBC·SYNC+. If you are using the shuttle mode of a VCR, this switch should be in the ON (up) position. If this switch is OFF, the TBC·SYNC+ will auto freeze during shuttle operations.

## Section 5 Alignment

This section provides the information necessary to adjust the preset controls to your exact system requirements and to allow correction of possible drift in factory settings as the equipment ages. We recommend adjustments be made by qualified service personnel. In no case should you remove the cover and attempt these adjustments without first completely familiarizing yourself with the system and observing the reasonable safety requirements inherent in this electronic device. Failure to exercise care may result in the voidance of the equipment warranty and is entirely the responsibility of the operator.

### Section 5.1 Installation Adjustment

The TBC•SYNC+ is preset at the factory to normalized values for all controls and should be very close to optimum for most applications. If, however, in operation one or more controls needs to be set manually, the internal preset controls may be adjusted to compensate for your system.

The following table lists the controls and their locations.

*Table 5-1. Internal Preset Controls*

Control	Preset Switch	Reference	Location
Video Level	Yes	R53	Right of manual pot
Setup Level	Yes	R82	Right of manual pot
Chroma	Yes	R87	Right rear of manual pot
Hue	Yes	R83	Left front of manual pot
H $\phi$	No	R139	Adjustable from front
SC $\phi$	No	R140	Adjustable from front

**Note**

R139 and R140 may be adjusted from the front without removing the top panel.

The following procedure describes the steps necessary to make internal control adjustments.

1. Allow the TBC•SYNC+ to warm-up and stabilize its internal temperature for at least 10 minutes before proceeding.
2. Remove the six screws securing the case top.
3. Refer to the adjustment location drawing (Figure 5-1) to determine the physical location of the desired pot.
4. Push the required knob IN to enable the preset mode.
5. Remove the case top and with a small, insulated adjustment tool make the adjustment required.

**Note**

Do not leave the case top off for any longer than necessary to complete the adjustment. The top is essential for providing proper air flow to the TBC•SYNC+ circuitry. Removal of the top will destabilize the temperature and expose the operator to unshrouded fan blades and 117 VAC wiring.

6. Replace the case top and secure with six screws.

Figure 5-1 shows locations for internal control adjustments.

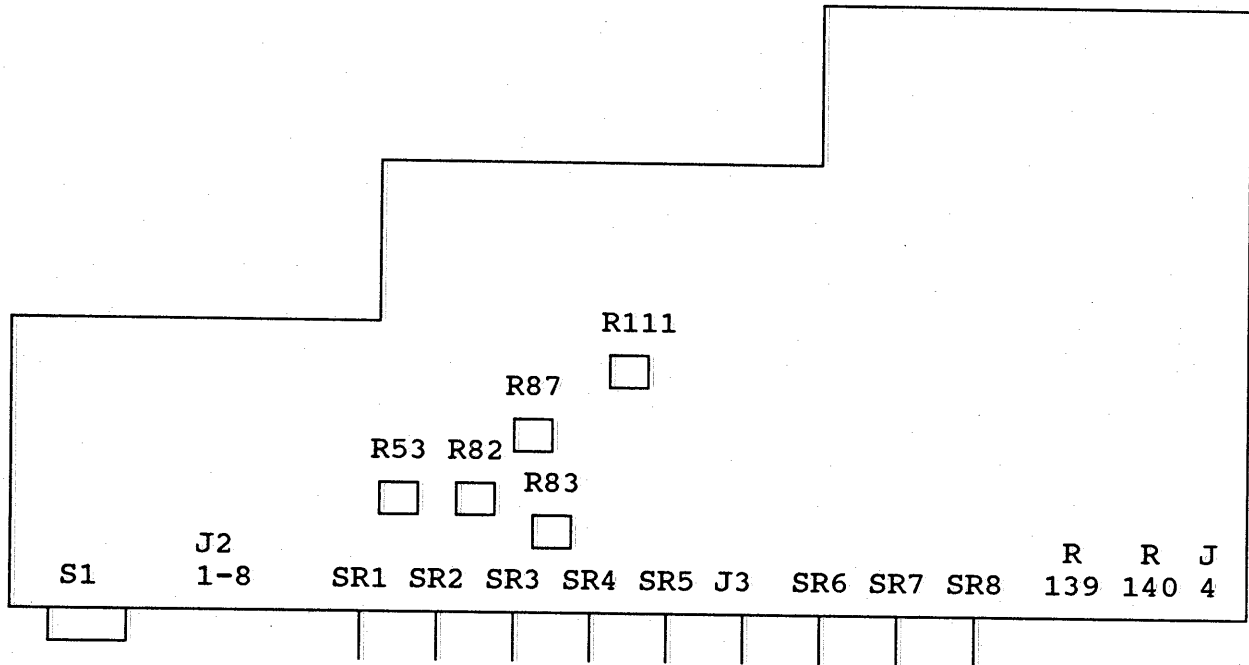

Figure 5-1. Internal Adjustment Locations (top view of bottom PCB)

## Section 6 Servicing

---

This section gives you information about maintaining your TBC • SYNC+ System, obtaining service, and troubleshooting.

### **Routine Maintenance**

The TBC • SYNC+ System is inherently a low maintenance unit that requires only a periodic dusting internally, when used in an unfiltered environment. The fan is a sealed bearing, brushless DC unit that should be replaced every 5 years of continuous duty operation.

### **Unit Malfunction**

All TBC • SYNC+ systems are designed and tested to perform as outlined previously in this manual. The manufacturer does not assume any responsibility for damage or malfunction resulting from operation of this unit outside the published environmental or interface specifications, or improper operation resulting from custom interfacing or any unauthorized internal modification.

If you encounter a malfunction during the warranty period, call your dealer or our Customer Service Department at the factory to arrange for service. **DO NOT** attempt to service this unit during the warranty period; to do so will void the warranty.

You may have out-of-warranty products repaired by your dealer or authorized repair facility.

### **Service Calls**

If you call for service, give the following information about your unit. It will help your dealer in diagnosis and repair:

1. The model and serial number of your unit.
2. The system configuration (including VCR types).
3. The problem you are having and the specific effect on the picture.

## Section 6.1 Troubleshooting

The following table provides troubleshooting information for frequently encountered problems:

*Table 6-1. Troubleshooting*

Condition	Possible Cause
Nothing happens at power ON.	Fuse blown. Line plug loose.
Fuse always blows at power ON.	Wrong line voltage.
Output video not corrected.	Bypass mode selected.
Output corrected but rolls vertically.	Recorder not V-locked, or Genloc input missing.
Output corrected but picture not framed horizontally.	Misadjustment of H $\phi$ pot R111 (See Figure 5-1).
Drop-outs evident on screen.	Misadjustment of DOC threshold. RF not connected to DOC IN J8.



## Guarantee

Since Prime Image first opened its doors in 1985 our goal has been to ensure that our customers are completely satisfied everytime they do business with us.

Prime Image prides itself on engineering, producing, testing, marketing and servicing the finest line of video processing equipment in the industry.

Prime Image customers are supported and serviced in every way possible to ensure that the optimum benefits of our products are realized.

**3 Year  
Limited  
Warranty**

The Prime Image limited three year warranty provides for parts, labor and Federal Express shipping at no charge to our customers.



**Prime  
Image**

19943 Via Escuela  
Saratoga, CA. 95070

# Warranty Cards

---

NAME

---

COMPANY NAME

---

ADDRESS

---

CITY STATE ZIP COUNTRY

---

TELEPHONE NUMBER

## PLACE OF PURCHASE

---

DEALER NAME

---

ADDRESS

---

CITY STATE ZIP COUNTRY

---

PURCHASE DATE

---

SERIAL NUMBER

## PLEASE CIRCLE TYPE OF BUSINESS

Agriculture

Real Estate

Construction

Business Services

Manufacturing

Health Services

Transportation

Recreational Services

Utilities

Public Services

Wholesale Trade

Educational Services

Resale Trade

Broadcast

Finance

Cable Television

Insurance

Production Facility

---

OTHER BUSINESS

---

COMMENTS