

HIGH
PERFORMANCE
GENLOCK
FOR THE AMIGA®

GenLock™

HIGH PERFORMANCE GENLOCK



GREAT VALLEY PRODUCTS, INC.
600 CLARK AVENUE • KING OF PRUSSIA, PA 19406
PHONE 215•337•8770 FAX 215•337•9922
For technical support call 215•354•9495

GenLock is a trademark of Great Valley Products, Inc.
Amiga is a registered trademark of Commodore-Amiga, Inc.

©1992 Great Valley Products, Inc.
All rights reserved

GenLock™

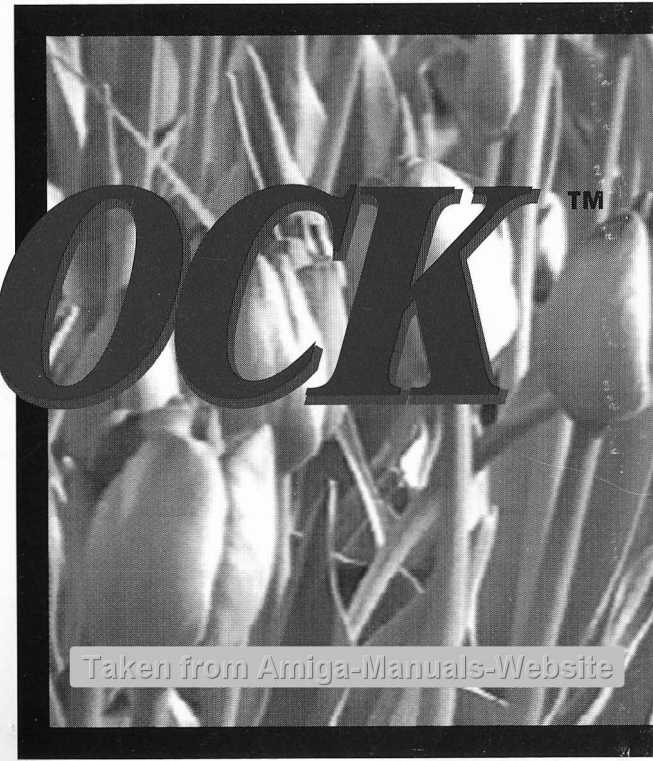

USER'S GUIDE



Scanned by John



G-Lock

**The ultimate
Genlock**

**From
Great Valley
Products**

Scanned by John



This manual, the G-Lock Genlock, distribution disks and all related materials are copyright 1992, Great Valley Products, Inc. (GVP). All rights reserved.

WorkBench, Kickstart, Amiga, A500, A600, A2000, A3000, A3000T, A4000, AA, AmigaDOS and Display Enhancer are all registered trademarks of Commodore International, Ltd. Digl-View is a trademark of NewTek, Inc. Flicker-Free Video is a trademark of ICD, Inc.

All other product trade names and designations are used for illustrative purposes only and are in no way endorsements of those products or infringements on the copyrighted properties of their manufacturers.



TABLE OF CONTENTS

1. Introduction	1
2. Ready, Set, Go!	5
3. Tutorials	11
4. Hardware Reference	15
5. Software Reference	20
6. Advanced Mode Control Panels	35
7. Special Features	45
8. Questions and Answers	48
9. Glossary	51
Appendix A: Technical Reference	56
Appendix B: Kybd. Shortcuts & Hotkeys .	66
Appendix C: Tool Types	68
Appendix D: CLI Parameters	69
Appendix E: AREXX Reference	73
Appendix F: Customer Support	77
Appendix G: Problem Reporting	78
Index	81



FCC STATEMENT

WARNING: This equipment has been designed to comply with the limits for a Class B computing device, pursuant to Part 15 of the Federal Communications Commissions rules. These rules and regulations are designed to provide reasonable protection against radio and television interference in a residential installation. If not installed properly, in strict accordance with the manufacturer's instructions, it may cause interference. If you suspect interference, you can test this equipment by turning it on and off. If you still experience interference with the equipment switched off, then the cause lies elsewhere. If this equipment does cause interference when switched on, any or all of the following suggestions may correct the problem.

- Reorient the antenna or plug on the radio or television receiver
- Change the relative positions of the GVP equipment and the radio or television receiver
- Plug the GVP equipment into a different outlet so that the peripheral and radio or television receiver are on different circuits.

CAUTION: Only equipment with shield-grounded cables (computer input-output devices, terminals, printers, etc.), certified to comply with Class B limits, can be attached to this device. Operation with non-certified equipment may result in communications interference.

Your house AC wall receptacle must be a three-pronged type (AC grounded). If not, contact an electrician to install the proper receptacle. If a multi-receptacle switch box or "power strip" is used to connect the computer and GVP peripherals to AC, then all receptacles must share a common ground.

If necessary, contact your dealer or an experienced radio-TV technician for additional suggestions. You may find the following FCC booklet helpful: "How to Identify and Resolve Radio-TV Interference Problems." The booklet is available from the U.S. Government Printing Office, Washington, D.C. 20402, stock no. 004-000-00345-4.



CHAPTER 1.

INTRODUCTION

Thank you for purchasing G-Lock, the first Amiga product to integrate a high quality video genlock and audio mixer into a simple-to-use, powerful and affordable unit. Designed to be used with any Amiga, in either NTSC or PAL television standards, the G-Lock allows you to combine the power of the Amiga computer, and your video and audio equipment to enhance home video presentations and productions.

G-Lock is as simple to operate as Ready, Set, Go! This manual is designed to get your G-Lock up and running quickly. For a fast start, read as a minimum Chapter 2, and before you do anything, back-up G-Lock's software.

Hardware and Software Features

G-Lock is an external genlock and audio mixer that requires no additional power supply and connects directly to the Commodore Amiga. Its many features include the following:

- High quality genlock with output switchable between NTSC or PAL.
- Input video software switchable between two composite sources or one Y/C (Hi8 or S-Video) source.
- Transcoder operation provides simultaneous high quality composite, Y/C and RGB outputs.
- RGB output switchable to provide YUV output.
- Real-time software control of many video attributes, such as brightness, contrast, hue, saturation, sharpness, filtering gain and more.
- Color filter circuit for special effects.

Scanned by John



- Can convert most SECAM video sources into VCR quality PAL video.
- Keyer modes include Amiga only, External Video only, Overlay, and Inverse Overlay modes *plus* control of Amiga ECS/AA special effects!
- Audio processor allows software switching and mixing of two separate monaural sound sources and control of volume, treble, and bass.
- Unit operates as an adjustable electronic RGB color splitter for direct use with the NewTek Digi-View or other slow-scan video digitizers.
- Works with the Display Enhancer/FlickerFreeVideo boards for simultaneous genlocked video and de-interlaced Amiga graphics output.
- Intuition-based software control panel with full ARexx and CLI interfaces. Example AmigaVision flow and ARexx scripts are provided.
- Transitions controlled with ARexx. (*Examples include simple A/B roll, fade to black, etc*).
- Completely self-contained unit requiring no external power supply.
- Works under AmigaDOS 2.0 and 1.3 (AmigaDOS 2.0 or greater recommended).
- Advanced user menus.
- Hot-keys for all Kickstart versions, under AmigaDOS 2.0 hot-keys can be changed.



- GVP custom designed VLSI for lowest possible component count, combined with surface mount technology result in more reliable assembly and longer service life.

Required Equipment

Computer System Requirements

G-Lock will work with any NTSC or PAL-based Amiga having at least 512k of memory and version 1.3 or greater Amiga operating system. If G-Lock is multitasked or operation under ARexx control is planned, a minimum of 1 megabyte of chip memory is required. Enhanced operation will be realized on computers having the Enhanced Chip Set (ECS), expanded memory (fast ram), hard drives, or accelerated CPU's. G-Lock is compatible with Advanced Architecture (AA) chip set based Amigas, like the A4000.

G-Lock is powered directly by the Amiga. While power requirements are minimal, the A500, A500 Plus and A600 series computers may be limited in the number of other peripherals that can be attached. Please consult your Amiga reference manual for specific recommendations.

G-Lock's system software can be run directly from the supplied floppy or from your hard disk.

Video Requirements

G-Lock is calibrated for either NTSC or PAL operation, depending on the country in which it was purchased. It is possible on Amigas equipped with the ECS chip set to switch between NTSC and PAL modes by software control. Also, SECAM video sources can be converted to PAL, although the output quality will be somewhat reduced (*refer to Chapter 7 for more information*). In every case, supplying the highest quality input video signal will insure the best possible output quality.

G-Lock is designed to be used with the following external video and audio equipment:

- Camera - as a live video source
 - Composite
 - S-Video (Y/C) Hi8 and S-VHS
- VCR, VTR, camcorder, or laserdisc player
 - Composite
 - S-Video (Y/C) Hi8 and S-VHS
 - RGB/YUV with separate syncs (from G-Lock only)
- CD or cassette player
- Monitors
 - Amiga RGB monitors (1080, 1084, 1084S, 1950, 1960)
 - Studio monitor, TV receiver

Using the Manual

G-Lock is simple to connect and operate. The process does involve some special cabling and software installation. Chapter 2, Ready, Set, Go!, is intended to get things up and working in the least amount of time possible. Chapters 4, 5 and 6 will provide more detailed information on all aspects of the hardware and software features and operation. Some users may find it helpful to begin with Chapter 8, which presents a number of frequently asked questions and answers them. If you are new to video and need to understand the terminology better, refer to the Glossary in Chapter 9. We also recommend reading "Amiga Desktop Video Power" by Guy Wright, published by Abacus Software.

Appendix A, Technical Reference, provides additional detail for advanced users and video engineers. Most users may find information in this section interesting to know, but not crucial to their understanding of the product.

For your convenience all software supplied with G-Lock is not copy protected. Be sure to safeguard your original disk by making a working copy. If you're not sure how to do this consult your Amiga reference manual on making disk copies.

CHAPTER 2.

READY, SET, GO!

Ready - Cable and Equipment Connection

G-Lock is ready-to-use right out of the box. No adjustments or modifications should be necessary under normal conditions. Simply connect G-Lock to your Amiga, connect your video and audio equipment to G-Lock, install system software as described in this chapter, and production can begin. While there are numerous ways to connect G-Lock, the most basic set-up is described below and depicted in figure 1. Please follow this sample set-up and the following procedures carefully. More setup examples and tutorials can be found in Chapter 3, Using G-Lock.

NOTE: Before attempting to connect G-Lock to your Amiga, always make sure all computer equipment is switched OFF.

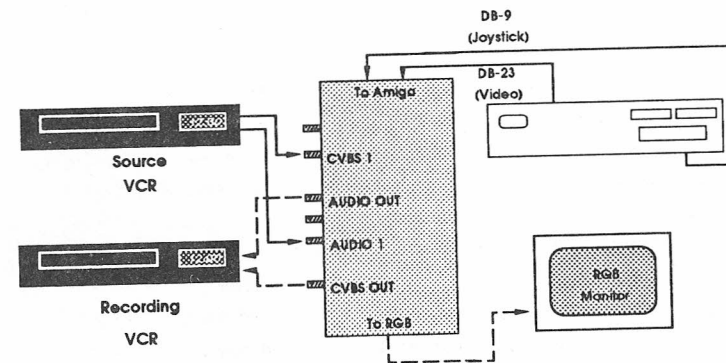

Figure 2.1 - Basic G-Lock Configuration



Connecting G-Lock to the Amiga

There are two cables to connect; one from the G-Lock genlock, and one from the Amiga. Begin by switching off power to both computer and monitor.

- Disconnect the 23 pin RGB monitor cable from the back of the Amiga, then plug the 23 pin connector from G-Lock's video port interface cable into the Amiga's 23 pin video port.
- Next, connect the 25 pin connector of the G-Lock interface cable to the genlock connector labeled TO AMIGA. To insure the best possible signal and prevent accidental disconnect, be sure to firmly secure the cable interface to the computer and genlock by tightening both thumb screw sets.
- Now plug the 23 pin connector from your Amiga RGB monitor into the genlock connector labeled TO RGB MONITOR.
- Finally connect the genlock 9-pin cable interface to the Amiga's joystick port #2. The location of this port varies depending on the Amiga model. Please consult your Amiga reference manual if you are not sure which port this is.

This completes the connections to the Amiga.

Users with Commodore's 1950/1960 multisync monitor should use the 15 to 23 pin adapter supplied with the monitor for connection to the G-Lock unit. Users of A3000's or Amiga's equipped with deinterlacer cards can have two monitors connected to their system. An RGB multisync monitor could be connected to the deinterlacer DB15 connector for Amiga-only deinterlaced output. Another monitor, such as Commodore's 1084S, could be connected to G-Lock's 23-pin connector for viewing the genlock output.



Connecting Video and Audio Equipment

Now connect your video and audio equipment to G-Lock as suggested in figure 2.1. Consult your video and audio equipment reference manuals for the exact names of these input and output connections. Start the equipment cabling by first connecting the video output from any composite source (*camcorder, VCR, laserdisc, TV, etc*) to the CVBS1 (*composite input #1*) connector on G-Lock.

Note: All composite video connectors, and all audio connectors are of the RCA type. All Y/C (Hi8 or S-Video) connections use standard 4-pin Mini-DIN connectors. These cables are available at most radio and television accessory stores. Using cables of the highest quality and shortest length will insure the best possible results with the least amount of signal loss and interference. High quality 75 ohm shielded cable should be used for video, and can also be used for audio connections.

Next connect the audio output from composite input source #1 or any other audio source to G-Lock's Audio 1 (*audio input #1*) connector.

Note that G-Lock only accepts monaural input. If the source audio is stereo, it will be necessary to combine the left and right audio channels. This is usually accomplished with a "Y" cable, available at most radio or television accessory stores. This is important to keep in mind when using Amiga generated music or sound effects to enhance your videos. Use a "Y" cable to combine the left and right Amiga audio channels, then connect its single line to either of G-Lock's audio inputs. If MIX is selected from the Audio Panel, the video's audio will be mixed with the Amiga's sound in the final combined output.

Finally, referring to figure 2.1, connect a cable from the G-Lock CVBS OUT (*composite output*) connector or S-VHS (*Y/C output*) to the video input of your recording VCR or camcorder. Also connect the G-Lock AUDIO OUT to the monaural audio input jack of this VCR or camcorder.



This completes the equipment set-up. You can now install the system software as described in the next section.

NOTE: If a second composite video and second audio source is desired, connect their inputs to G-Lock's CVBS2 and Audio 2 inputs.

Set - Install Software

All of the control software for G-Lock is located in the CP drawer of the included program disk. The main program is named GL. This control program can be started from Workbench or CLI via floppy disk or hard drive. To install the software on a hard drive, open the CP drawer and double-click on the install icon. Then follow the installation prompts.

With G-Lock correctly connected (*see figure 2.1*), turn on your Amiga and its monitor and boot-up in the normal manner. When the Amiga powers-up, the only valid G-Lock output is from its RGB output connector. At this point the genlock is not functioning as an encoder or genlock, but is simply passing the Amiga RGB signal through. None of the other outputs will produce a valid video signal until the genlock is initialized in the next step.

Go! - Initialize G-Lock

Loading the G-Lock software and initializing the genlock is a two step process involving an automatic reboot of the Amiga, and then rerunning the G-Lock control program GL. The first step in starting the genlock is to run the GL program from disk or from the directory in which it is located. When this program loads, a requestor will appear. The options presented will, depending on which is selected, either initialize G-Lock in preparation for genlocking, or cancel this request. One click within the QUIT button will abort the initialization of the genlock and return you to WorkBench.

CAUTION: Be sure all tasks and disk activity is completed before selecting REBOOT.



If REBOOT was selected, the Amiga will automatically reboot itself, synchronize to G-Lock, and load WorkBench or your systems environment. The second and final step to running G-Lock is to again open the CP drawer and launch the GL control program, or give the appropriate CLI parameters if running from the CLI. Now because the genlock has been initialized by the first step, the main G-Lock control panel will load, and control the genlock. To view the source connected to CVBS1, click on OVERLAY and then click on the CVBS1 button. To hear the audio connected to Audio1 click on the Audio button in the top right corner of the current control panel. Then when the Audio Panel appears select the Audio1 button.

With the Amiga now genlocking, the control panel in view, and your video and audio equipment connected, video production can begin.

In summary, to start the genlock from Workbench open the GVP disk icon, open the CP drawer, then double-click on the GL icon. To start from CLI, supply the appropriate path and command name. (*Acceptable command-line parameters are listed in Appendix D.*)

NOTE: Under AmigaDOS 2.0 rebooting accelerated machines is sometimes unreliable. If after choosing to initialize the G-Lock your system hangs up during the automatic reboot, it will be necessary to manually reboot using the key combination Control-Amiga-Amiga. This is a known problem with Commodore's software reset code for accelerated machines.

Quitting G-Lock

When genlocking, the Amiga depends upon an external source for its video sync. If no active input video is attached to the genlock, G-Lock provides its own internal sync to the Amiga. But when an active video source is selected, G-Lock switches the Amiga to that source's sync pulse. This is important to remember when quitting G-Lock, because disconnecting or turning off that video source after quitting the GL control program will cause the Amiga to crash.

Scanned by John



The following two procedures are the recommended ways to quit G-Lock. The first allows G-Lock to safely quit, but leaves the Amiga genlocked. The second exits genlock mode without the need to cold boot the Amiga.

Procedure 1

Before selecting Quit Control Panel from the Project menu, turn off or disconnect all input video sources. Notice that the video panel status line indicates "No Video." Now select Quit Control Panel and the genlock program will be safely exited.

Procedure 2

This procedure does not require any input source(s) to be turned off or disconnected and will return the Amiga to your normal WorkBench screen mode, however an automatic system reboot will occur. Start by selecting Quit Control Panel from the Project menu. Next, double-click on the *BypassGL* icon located in the CP drawer. A requester will appear providing the option to automatically reboot the Amiga and in the process, return it to the screen mode chosen by WorkBench preferences.

Note: Be sure all work is saved and all disk activity is completed before selecting the Reboot option.

Once the reboot is accomplished, G-Lock is bypassed and the Amiga is running in its normal screen mode and its own sync. All video sources can be turned off or disconnected as desired. In the Bypass mode the only valid output from G-Lock in the RGB connector.

CHAPTER 3.

Using G-Lock - Tutorials

The tutorials given below demonstrate typical configurations and operating procedures. Additional uses of G-Lock such as an electronic color splitter can be found in Special Features, Chapter 7. More information on using G-Lock with ARexx and AmigaVision can be found in Appendix E.

Tutorial #1

In this tutorial G-Lock will be used to enhance a video tape by overlaying Amiga graphics and mixing Amiga audio with it. In addition to equipment suggested in the basic G-Lock setup described in Chapter 2, a "Y" cable will be needed to combine the Amiga audio channels for input to G-Lock. Because the genlock will be multi-tasking with both graphic and music programs of your choice, one megabyte of chip memory is required to try this tutorial.

With G-Lock setup and running and all video and audio equipment connected and powered up, you should see a blue screen with the G-Lock Video Panel superimposed on the left side monitor and G-Lock's title bar across the top of the screen.

Notice the status line on the Video Panel indicates NO VIDEO. Because G-Lock is running in the Standard mode with the factory default settings, no video or audio source is selected by factory defaults; so therefore the Video Panel status indicates NO VIDEO.

To view the connected video source, click the CVBS1 button. Video connected to CVBS1 should now appear behind the control panel. If not, check the input source, being sure it is connected to the correct jack.



Now click the Audio button on the Video Panel. The Audio Panel will appear. Click on Audio #1 and the connected source should now be heard through the output VCR's audio. Volume, treble, and bass for audio source #1 can be adjusted by moving the appropriate sliders.

This next step connects the Amiga's audio to the G-Lock. Attach a "Y" cable from the Amiga's left and right audio channels to G-Lock Audio #2. Click the Audio #2 button on the Audio Panel. Now run your music or sound effect and it will be heard through the output VCR's audio out.

With video and audio sources connected and adjusted, switch to the Video Panel and click on OVERLAY to overlay Amiga graphics. Switch to the Audio Panel and click on MIX 1 + 2. Then hide the control panel by clicking the button in the upper-left corner of the control panel or selecting HIDE from the project menu or use the Alt-F10 keys. Recording of the genlocked video and audio can now begin.

The Amiga graphics and music programs that will generate titles and sound effects should be started and cued up. Start the input VCR playing and the output VCR recording, then at the appropriate moments run the Amiga graphics and sound. Because the HIDE button has been selected, G-Lock's control panel becomes hidden allowing other Amiga programs to be activated. However, G-Lock can still be commanded through the available Hot-keys or by an ARexx script. The power made available by G-Lock to the video user can begin to be realized as Hot-keys are used to select or mix the available audio channels while overlaying the Amiga's graphics to the output tape.



Tutorial #2

This tutorial will demonstrate the ability to switch between video sources, using ARexx to automatically control the fading and switching of the video sources. Added to the basic system configuration, as shown in figure 2.1, will be an additional composite video source connected to CVBS2, and an additional audio source connected to Audio2.

Begin by connecting all equipment and initializing G-Lock. With G-Lock running, return to WorkBench and start up ARexx by double-clicking on the RexxMast icon located in the WorkBench *System* drawer. With ARexx running in the background return to G-Lock. Test the integrity of all connected video and audio sources, then use G-Lock's controls to adjust video levels and audio settings to suit production needs. It is not possible to separately adjust the two audio sources when using Mix 1 + 2. If the mixed audio levels are mismatched it will be necessary to adjust their levels in some manner before input to G-Lock. At this time run and test any Amiga graphic/titling program that will be used in the final output.

A sample ARexx script demonstrating a fade between two video sources is supplied with G-Lock. To test this effect, be sure ARexx is running and G-Lock's Video Panel keyer is in either Overlay or External mode. Select one of these keyer modes and, if desired, hide the control panel, then return to the CLI. Type:

```
RX FADE.REXX (the ARexx fade script)
```

but do not hit return. Be sure to provide the full path to both the ARexx command RX (*found in the Rxxxx drawer*) and the G-Lock fade script. Switch to the desired Keyer mode by using the ALT-F6 keys, but be certain to leave the CLI window active.



Now with both video sources on and connected to G-Lock, hit the return key. The screen should fade to black, then return showing the other video source. To repeat the effect, hit the up arrow key once and then the return key. If the CLI window is shown when the fade is completed, your second video source is either not connected or not on.

This simple script is provided to demonstrate how easy ARexx is to use and the powerful effects it makes possible. Combine the techniques explained in Tutorial #1 and you will be able to produce a video that has simple A/B roll effects and either overlays sound effects or audio track switching.

CHAPTER 4.

HARDWARE REFERENCE

Hardware Description and Operation

G-Lock is an extremely versatile genlock, capable of accepting two composite video sources or a single high quality Y/C input source, and simultaneously providing high quality Composite, Y/C, and RGB or YUV genlocked outputs. Additionally, the ability to accept two separate audio sources increases the units flexibility in video and multimedia productions.

G-Lock is a small unit with eight connectors, two interfaces, and one cable located around its sides. These connection are utilized in the following manner.

Video Inputs

- 2 composite sources
- 1 Y/C (Hi8 or S-Video) source

Video Outputs

- 1 composite video
- 1 S-Video (Y/C)
- 1 RGB or YUV

Audio Inputs

- 2 monaural audio sources

Audio Output

- 1 audio output software switchable between two monaural input sources, or optionally mixes the input sources.

Scanned by John

Computer Interface

- 1 Amiga interface 25 pin connector (uses supplied 25 pin to 23 pin cable) to obtain Amiga RGB Signals.
- 1 9-pin control cable interface

G-Lock Connections and Interfaces

Figure 4.1 identifies each of G-Locks connectors and interfaces. A detailed description of each connector follows this figure. Refer to Chapter 2 for detailed hook-up instructions, and Chapter 3 for examples of how G-Lock is used.

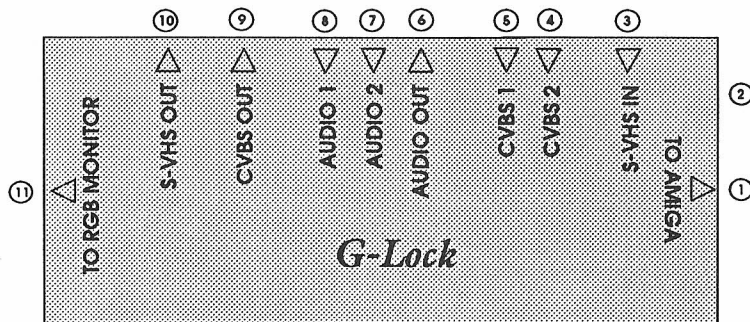

Figure 4.1 – G-Lock Connections

① TO AMIGA

25 pin RGB interface

The video port cable interface is attached to this connector and to the 23 pin video port connector on the back of the Amiga. Please be certain to firmly secure the cable to the genlock and computer by tightening the thumb screw sets. This will insure the best possible signal and prevent accidental disconnect. Note that only the G-Lock can use the video port, no other device or pass-through is supported.

② 9 pin cable interface

This cable connects to joystick port #2. G-Lock needs exclusive use of this port, so it will be necessary to disconnect anything that might be connected there.

Video Inputs

③ S-VHS IN

4 pin Mini-DIN connector for Hi-8 or S-Video (Y/C) Source.

④ CVBS2

RCA connector for Composite video source #2.

⑤ CVBS1

RCA connector for Composite video source #1.

CVBS1 and CVBS2 can be used to input two separate composite video sources, such as those supplied by a VCR, video camera, or laserdisc player. The 4-pin Mini-DIN S-VHS connector can be used to input the signal from any Y/C source, such as S-Video and Hi8 videotape or video camera equipment.

Although provision is made for multiple video inputs, G-Lock can process just one composite or one S-Video stream at a time. The actual selection of the two possible composite sources is performed in software, using the G-Lock Control Panel. Note that the S-Video input uses the same signal lines as CVBS1 and CVBS2. Therefore, you may only have up to two active composite sources or one active S-Video source on at a time. Attempting operation with both input types on and connected simultaneously will cause signal interference.



Audio Connections

⑥ AUDIO OUT

This RCA output connector provides two optional output modes. The first allows the selection of either of the two available audio inputs. It is possible, via software control, to adjust the volume, treble, and bass of either of these inputs. The second option allows you to combine the two available audio sources, providing an equal mix of these inputs. The volume, bass, and treble software controls will adjust the combined sources. However, in this mode it is not possible to separately adjust the audio sources or vary the ratio of audio mix. In both mixed or separate audio operation G-Lock can provide up to a 6 dB gain in volume. Note that the audio output can not power speakers directly.

⑦ AUDIO 2

RCA connector for audio source #2.

⑧ AUDIO 1

RCA connector for audio source #1.

These inputs accept only a monaural signal from any line level audio device.

Video Outputs

⑨ CVBS OUT

This RCA connector provides a composite video signal to a composite computer monitor, video monitor, VCR, or any other composite device.

⑩ S-VHS OUT

This 4-pin Mini-DIN connector provides a Y/C video signal out as separate Luminance and Chrominance channels suitable for a high quality Y/C video monitor, S-VHS or Hi8 VCR or a video digitizer.

⑪ TO RGB MONITOR

This 23-pin connector provides the genlock processed video signals directly to the Amiga RGB monitor, or for use with a YUV device. Selection of the YUV signal is controlled through G-Lock software (*see Chapter 5*). Using YUV devices requires special cabling not supplied with G-Lock. (*Pin-out information for the fabrication of this cable is found in Appendix A, Technical Reference.*) A custom cable is available directly from Redmond Cable, part number RCA685, D23F-4BNC.

Redmond Cable is reachable at the following address:

17371 - A1 NE 67th CT.

Redmond, WA 98052

Phone #: (206) 882-2009

FAX #: (206) 883-1430



CHAPTER 5.

SOFTWARE REFERENCE

G-Lock Control Program

The primary user interface for G-Lock is the *GL* program. This control program uses a combination of menus and panels that together control all of G-Lock's functions. The format and operation of the control program's interface conform very closely to AmigaDOS 2.0 style guides making them familiar, easy to learn and easy to use. The design of the control program also incorporates carefully chosen combinations of colors and graphics that allow its menus and control panels to be clearly read at a distance even on composite monitors.

The control program provides two optional operating modes: *Standard* and *Advanced*. Standard mode has two control panels, the Video Panel and the Audio Panel, each controlling a different aspect of G-Lock's performance. In Advanced mode there are up to 4 additional control panels allowing more control of video parameters and characteristics.

These advanced panels are intended for experienced video users and, therefore, are not normally accessible. (*Detailed descriptions of their capabilities and how to access them are found in Chapter 6.*)

An important G-Lock control program feature found on all control panels is the *Setup* function. Located at the bottom of each panel, these three buttons, Setup1, Setup2 and Setup3 are used to store and recall three separate sets of video and audio configurations. These setups can be used to retain G-Lock settings for different equipment configurations, or to facilitate quick comparison of experimental adjustments.

The G-Lock control program can be started from WorkBench or run from the CLI after the genlock is initialized. Once running, the GL control program can be hidden or recalled by using the available menus, or the default Hot-key combinations (*Alt-F10 and Alt-F1*), or by rerunning its icon.

G-Lock Standard Mode Menus

When G-Lock is started from WorkBench, a window will appear. Across the top of the window is the title bar with standard Amiga Front/Back buttons. If the G-Lock window is moved to the back and deactivated, remember to reactivate it when it is returned to the front by clicking anywhere within the control panel. The Alt-F1 keys will also recall the last control panel in use to the front. When a control panel is outlined in bright blue borders it is active. Placing the mouse pointer onto the title bar, then clicking and holding the right mouse button will reveal the available menus. Clicking and holding the left mouse button allows the window to be dragged down to reveal the window below.

There are three groups of menus - Project, Menu, and Extras. *Project* allows factory and custom settings to be loaded or saved, hiding the control panel, quitting the control program, or listing of the Hot-keys. *Menu* allows selection of all available control panels. *Extras* provides selection of the video checking status and access to the ILBM requestor. Figure 5.1 identifies the project menus. Following the figure is a detailed description of each menu and their use.

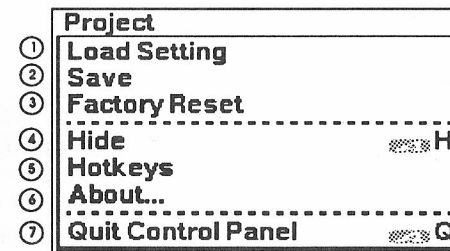

Figure 5.1 - Project Menu

Scanned by John



Project

① LOAD SETTINGS

The GL program can store three separate setups that allow video and audio settings to be customized and tailored to particular equipment configuration needs or production requirements. Use this menu and its submenus to load your most recently saved setup parameters from disk into the control panel.

THIS SETUP

Use THIS SETUP to load the last saved custom control parameters into only the Setup button currently selected on the control panel.

ALL SETUPS

Use ALL SETUPS to reload your last saved custom parameters for all setups into Setup 1, 2, and 3, respectively.

② SAVE

Save allows all control panel parameters, as they currently exist, to be saved to disk for future recall. If this is the first save, parameters will be based upon the factory settings and any changes you made to any of the control panels.

THIS SETUP

Use THIS SETUP to save the current custom control parameters for only the Setup button currently selected. Keyboard command is Right-Amiga S.

SETUP 1, 2, or 3

Choose Setup file 1, 2, or 3 to save the current settings into.

ALL SETUPS

Use ALL SETUPS to save the current custom configurations of all control panels into Setup 1, 2, and 3 buttons. Caution must be exercised when using this command as all previously saved G-Lock Standard and Advanced mode control panel settings will be erased and replaced by the current configuration. All Setup buttons will return identical parameters after this save command is used.

③ FACTORY RESET

G-Lock has on-board read-only memory in which factory settings are permanently stored. The control program uses this as its parameter baseline and can always be recalled. The advantage of this capability is that at any time any or all of G-Lock's Setup buttons can be returned to stable baseline parameters. The available submenus allow the resetting of any or all setups.

THIS SETUP

Use THIS SETUP to restore factory parameters to only the Setup button currently selected. Keyboard command is Right-Amiga F.

SETUP 1, 2 or 3

Restore factory default settings to any one of these Setup buttons.

ALL SETUPS

Use ALL SETUPS to restore factory parameters to Setup 1, 2, and 3. Caution is advised when using this command, as all settings stored in the Setup buttons will be replaced by factory defaults. However, as long as the reset buttons are not saved, the previous setting configurations can be recalled by either reloading using PROJECT/LOAD SETTING or quitting G-Lock and then restarting the GL program.



④ HIDE

Selecting this menu item or clicking on the button in the upper-left corner of any control panel will remove the G-Lock control panel in use. In the process all possible memory is released, while still allowing complete control by Hot-key commands, ARexx commands via Shell.GL, or an ARexx script. The keyboard command for hide is Right-Amiga-H. Hot-key Alt-F1 recalls the control program and Alt-F10 hides the program.

⑤ HOT-KEYS

Most features of the G-Lock system that are addressable through the GL control program can also be accessed by combinations of keystrokes, which are called *Hot-keys*. Under AmigaDOS 2.0 the definitions for these Hot-keys can be changed by editing the GL.info icon file. Use the WorkBench Icons/Information menu item to change the ToolType for each function to your own preference. Refer to your AmigaDOS 2.0 reference manual for more information on changing ToolTypes. A description of each Hot-key follows.

Alt-F1

Returns (*pops-up*) the hidden control program user interface, calling the last control panel in use.

Alt-F2

Displays a previously loaded ILBM image or calls the G-Lock ILBM Loader if no image has been loaded.

Alt-F3

Switch to the composite video signal available at the CVBS1 input, if any.

Alt-F4

Switch to the composite video signal available at the CVBS2 input, if any.

Alt-F5

Switch to the Y/C video signal available at the S-VHS input, if any.

Alt-F6

Switches between External, Overlay, or Amiga video keyer modes.

Alt-F7

If in Overlay mode, toggles Inverse overlay mode.

Alt-F8

Switches between Audio 1, Audio 2, and Mix 1 + 2.

Alt-F9

Toggles Mute on and off.

Alt-F10

Hides control program user interface.

HELP

This key acts like an undo command, toggling between the last G-Lock action and the previous action or setting made.

SHIFT-HELP

Reset to last saved custom setting.

Alt-HELP

Reset to factory default setting.

⑥ About

Reveals G-Lock program version number.



⑦ Quit Control Panel

Quits G-Lock and releases all of its allocated memory. Even though the GL program is terminated, the Amiga will remain genlocked. In order to stop the genlock mode it will be necessary to either turn off the Amiga and perform a cold boot or use the *BypassGL* icon. (More information on quitting G-Lock can be found in Chapter 2.)

NOTE: If G-Lock is quit with active and selected video sources still connected to it, do not disconnect or turn those video sources off. Doing so will cause the Amiga to crash due to a loss of sync. If however, all active sources are first turned off or disconnected before quitting, G-Lock will switch to "No Video" mode. Now because the Amiga is synchronized to the G-Lock it is safe to quit without fear of a system crash.

MENU

This menu allows the selection of the two Standard control panels, and any available Advanced control panels when Advanced mode is enabled. Figure 5.2 shows the Standard Mode menu item. Figure 5.3 shows the Advanced Mode menu with all possible control panels. (Please see chapter 6 for information on obtaining the Advanced mode menu items.) The panels can be called into control by menu selection or if the control program is active by using the key combinations shown in each menu.

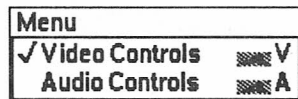

Figure 5.2 - Standard Mode Menu

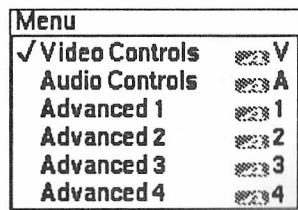

Figure 5.3 - Advanced Mode Menu

EXTRAS

This group of menus control the state of the Continuous Signal Checking option and the ILBM loader.

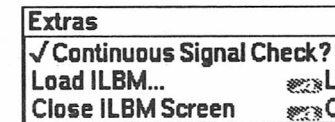

Figure 5.4 - Extras Menu

Continuous Signal Check

When G-Lock is initialized and in use this option must always be on. A check mark indicates Continuous Signal Check is on. G-Lock constantly checks for the presence of a valid video signal once every second.

If all input video signals are disconnected or lost, G-Lock will sense this and automatically switch to the NO VIDEO status. If this option is disabled and all valid video is lost the Amiga will eventually crash. This option should only be disabled when not genlocking and no video is present. If the operation of other tasks, such as word processors or graphics programs are adversely affected, this option can be turned off or the checking interval can be adjusted by modifying the appropriate WorkBench ToolType. G-Lock's priority may also be adjusted using a ToolType to decrease any adverse effects. (Appendix C lists all available ToolTypes.)

Scanned by John



Load ILBM

When loading an ILBM file with G-Lock use this loader. Selecting this option causes a load requestor to pop up on the G-Lock screen. Using the G-Lock ILBM loader will force the image to load in interlaced mode, which is necessary for proper genlocking, and also insures that any settings made by the ECS Panel (*an Advanced mode control panel*) are properly invoked. Call the requestor into control by menu selection or if the control program is active by using the Right-Amiga-L key combination. Note that all other keyboard equivalents are inactive while the loader is present.

Once the ILBM file is loaded it can be moved behind the current G-Lock control panel screen by double-clicking anywhere on the image. Recall a loaded image by double-clicking outside of the current G-Lock control panel.

Only one file is stored in memory at a time. Rerunning this command replaces the previously selected ILBM file with the new one.

Close ILBM Screen

Selecting this menu option will close an image loaded via G-Lock's ILBM Loader and delete it from memory.

G-Lock Standard Mode Control Panels

Video Panel

This panel is the main video interface for G-Lock. Through it control and adjustment of the contrast, brightness, hue, and saturation of the video, plus choice of genlock keyer mode is possible. Figure 5.5 identifies the Video Panel controls. The section that follows describes how the controls are used.

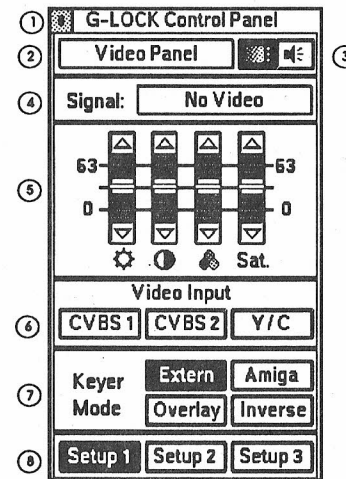

Figure 5.5 - Video Panel

This control panel, and all other G-Lock control panels can be dragged to any area of the screen by placing the mouse pointer over the panel's title bar, holding down the left mouse button, and then dragging to the desired location. The panel also has two buttons, located in the top right corner of the panel, that quickly call either this panel or the Audio Panel to the front screen. Key combination Amiga-V will recall this panel to the front screen.

Scanned by John



The Video Panel is divided into three functional groups of controls that together indicate genlock status, provide video control through various sliders and buttons, and the Setup buttons which allow saving or recalling custom setups.

① HIDE

Clicking on this button, or selecting this item from the menu will remove the G-Lock control panel. In the process all possible memory is released, while still allowing control by Hot-key commands, ARexx commands via Shell.GL, or an ARexx script. The keyboard command for *Hide* is Right-Amiga-H. Hot-key Alt-F1 recalls the Control Program and Alt-F10 hides the program.

② Status and Slider Value Indicator

This area of the Video Panel contains a status window that identifies the selected control panel and will change to indicate the current level or setting when any video input control slider is activated. This status window changes color to indicate levels that are at or near factory settings. Green indicates the factory setting, while white indicates user selected levels. Up and down carets indicate the factory setting for the selected slider. A single caret means the selected slider value is within one increment of the factory default. Both carets mark the exact factory default. An additional character, an asterisk, marks the last saved user setting.

③ Video and Audio buttons

Along side this status line are the video and audio control panel buttons. Depressing the inactive button brings that panel into control. These buttons are also common to all advanced control panels. On the advanced panels selecting either of these buttons will call the appropriate panel into control.



④ SIGNAL

This status line indicates the type and condition of detected video. There are ten possible states:

NTSC-Color, NTSC-B/W, NTSC-Colorkill, PAL-Color, PAL-B/W, PAL-Colorkill, SECAM-Color, SECAM-B/W, SECAM-Colorkill and No Video

⑤ VIDEO CONTROL SLIDERS –

Brightness, Contrast, Hue and Saturation

These four sliders adjust the brightness, contrast, hue, and saturation of the selected video source. As each slider is adjusted its value is shown in the video status window, and, again, colors and symbols indicate factory settings and last saved user settings.

The rate of change for all sliders can be controlled depending on how they're selected or moved. Clicking on the arrows at the top or bottom of each slider or in the area between either arrow and its slider will increment the controls value by one unit. Finally, clicking on a sliders and dragging it will increment the value by two units. The range of adjustment for all video sliders is 0 to 63. Note that the range of the brightness slider adjusts only between the value of 20 and 45. This limited range has been chosen to avoid problems with the picture level being mistaken for the sync signal.

The range limits of the brightness slider can be modified if desired, by changing their tool type default setting. It is suggested that the minimum value of the brightness slider never be set below the value of 15.



⑥ Video Input – CVBS1, CVBS2, Y/C

These three buttons allow the selection of any single video input source. CVBS1 and CVBS2 are composite inputs and can be either NTSC, PAL, or SECAM formats. The Hot-keys for selecting these inputs are Alt-F3 and Alt-F4. Y/C can be any S-Video input (*NTSC, PAL, or SECAM*). Its Hot-key is Alt-F5. The video source selected is under direct control of the brightness, contrast, hue, and saturation sliders.

⑦ KEYER MODE

These four buttons determine how the video will go out from G-Lock's video outputs. Because of G-Lock's transcoder abilities any selected input, composite or Y/C, will be available as high quality Composite, Y/C, and RGB/YUV outputs.

EXTERNAL

Passes the external video signal straight through to all outputs.

AMIGA

Sends the Amiga generated display out to all video outputs.

OVERLAY

Takes external video overlaying it with Amiga generated graphics and passes the combined display to all video outputs.

The Hot-key combination for cycling through these three functions is Alt-F6.

INVERSE

Selecting Inverse reverses the overlay effect rendering transparent all parts of the G-Lock display that are not defined as key colors. The Hot-key combination to toggle inverse mode is Alt-F7.



⑧ SETUP 1, SETUP2 and SETUP3

By using the G-Lock menus it is possible to load, reset, or save separate sets of video and audio configurations into these buttons. Use these three buttons to select between the separate sets of configuration settings.

Audio Panel

The Audio Panel is the audio interface for G-Lock. With this panel the user can choose between two separate audio inputs, or combine them into a single mixed output and adjust the volume, bass, and treble. Figure 5.6 identifies the Audio Panel controls.

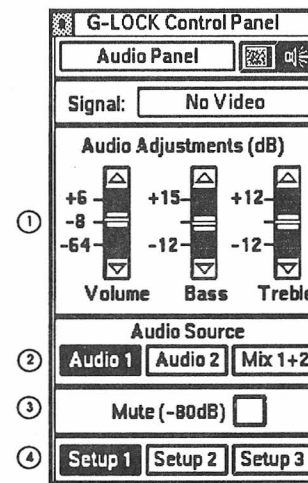

Figure 5.6 – Audio Panel

The Hide button, Status Line, Signal line, Video and Audio Panel buttons, and the three Setup buttons are identical in operation to the Video Panel. Please refer to that section for detailed explanation.



① AUDIO CONTROL SLIDERS

Volume, Bass and Treble

These three sliders control the volume, bass, and treble of the selected input audio source. As each slider is adjusted its value is shown in the audio status window, with colors and symbols indicating factory settings and last saved user settings. The rate of change for all sliders can be controlled depending on the manner in which they are moved. It is possible to drag the slider bar, click on either up or down arrows, or click in between either arrow to effect changes in control settings.

② AUDIO SOURCE

AUDIO 1 and AUDIO 2

These buttons will select either available audio inputs and pass it to the output connector. The volume, bass, and treble controls can modify the respective levels of the selected input source.

MIX 1 + 2

This button will combine the two available audio inputs in equal ratios (50/50). The volume, bass, and treble controls can still adjust the combined audio. It is not possible, in this mode, to separately adjust the individual audio sources.

③ MUTE

This button mutes the selected audio source or sources, providing a full -80 dB mute. A check mark indicates this option is active.

④ SETUP 1, SETUP 2, and SETUP 3

These buttons function as described in the Video Panel section.



CHAPTER 6.

ADVANCED CONTROL PANELS

As configured by internal factory settings, G-Lock initially will start up in the standard mode. This mode provides the most important features and capabilities needed to enhance home videos and most professional productions.

For experienced users and video technicians, the *Advanced Mode* of operation is available. In this mode up to four advanced control panels allow the fine tuning and adjustment of input video sources, the selection of alternate video modes, and the direct control of all special effects and features. Many adjustments available through these advanced control panels require specialized video calibration and test instruments to be properly and effectively utilized. For this reason these control panels are not initially available under G-Lock Standard Mode. It is a simple matter to obtain access to them. A one line modification to the G-Lock WorkBench icon ToolType will enable all possible advanced menus. Add the following entry:

MENUS=ADVANCED

(Refer to Appendix C for more Tool Type information.) After the Tool-type is correctly invoked, and G-Lock is rerun, the advanced menus will become available.

The ability to quickly and easily restore G-Lock to its factory defaults will allow even novice videographers to safely experiment with G-Lock's advanced features. If after trying different settings, the video becomes worse than when started, simply use PROJECT/FACTORY RESET from the G-Lock menu to restore any or all Setups.

In the following sections the operation and capability of each advanced control panel will be explained in detail.

Advanced Panel 1 – 1: Proc Amp 1/2

This control panel is especially important to PAL and SECAM users. G-Lock tries to automatically sense the video standard of the incoming signal and switch to that mode. Occasionally due to poor signal quality, G-Lock will not be able to automatically select the proper mode. This panel allows manual control of this operation.

Other panel features allow the selection of the best horizontal timebase, the fine adjustment of gain balance, subcarrier phase, and saturation balance, and a button for creating a black and white special effect for all input sources.

Figure 6.1 shows the Advanced 1 panel. If the GL control program is active, the keyboard combination Right-Amiga-1 calls this panel into control.

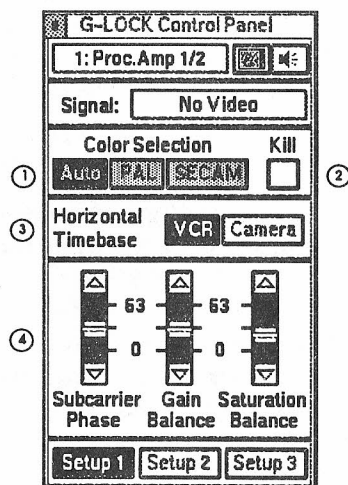

Figure 6.1 – Proc Amp 1/2 Control Panel

The Hide button, Status Line, Signal line, Video and Audio Panel buttons, and the three Setup buttons are identical in operation to the Video Panel. Please refer to that section for detailed explanation.

① Color Selection

Normally when using PAL or SECAM video the AUTO button should be depressed, allowing G-Lock to automatically sense the video input. But if the quality of the input video is poor, it may be necessary to force G-Lock into the desired mode by selecting either the PAL or SECAM button, depending upon the desired input source standard. These buttons have no use when running in NTSC modes, and therefore will be ghosted.

② Kill

Selecting this box kills the color, producing a black and white image. This option is available for all video standards. A check mark indicates this option is invoked.

③ Horizontal Timebase

G-Lock syncs to the quality of the input video source. If the quality of this input is poor the stability of the Amiga display will be adversely affected. These buttons allow the selection of the most stable or best quality video signal-type anticipated. In most instances this will be a VCR. If using a de-interlacer and a VCR this setting should always be VCR. This setting will produce the best quality output from the de-interlacer as well as the genlock.

④ VIDEO TUNING SLIDERS

Subcarrier Phase

This slider fine tunes the Hue by plus or minus 5 degrees and provides correction for subcarrier reference errors.

Gain Balance

R-Y/B-Y gain balance of the decoded video.

Saturation Balance

Controls the color saturation balance of the video signal's R-Y/B-Y components.

Advanced Panel 2 - 2: Proc Amp 2/2

This panel allows fine adjustment and control over the output RGB signal. It also allows, when selected, the saturation levels of both input Amiga RGB graphics and the input video source to be simultaneously adjusted.

Figure 6.2 shows the Advanced 2 panel. If the GL control program is active, the keyboard combination Right-Amiga-2 calls this panel into control.

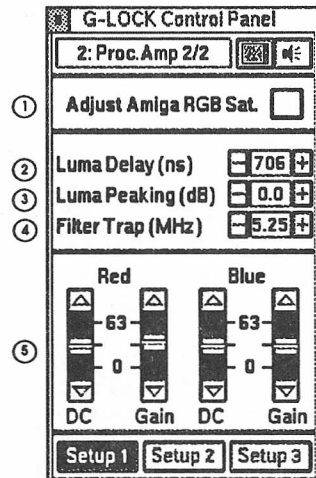

Figure 6.2 – Proc Amp 2/2 Control Panel

The Hide button, Status Line, Video and Audio Panel buttons, and the three Setup buttons are identical in operation to the Video Panel. Please refer to that section for detailed explanation.

① Adjust Amiga RGB Saturation

Selecting this block allows simultaneous adjustment of the RGB saturation levels of both Amiga graphics and source video. As normally selected, the saturation slider on the Video Panel will adjust only the saturation level of the selected input video source. A check mark indicates this option is active.

② Luma Delay (nS)

This slider allows you to compensate for any misalignment between the Luminance and Chrominance channels of a video signal after they have been processed. This misalignment may appear as a horizontal blur or fuzziness. Acceptable values are 594 to 882 nS.

③ Luma Peaking (dB)

Peaking provides a way of increasing the apparent sharpness of the image. Acceptable values are 0 to 5.4 dB.

④ Filter Trap (MHz)

Some video equipment will combine one or more audio tracks into a Composite video signal. These occur at various VHF band frequencies and can often introduce signal interference into the image data. G-Lock includes a notch filter to separate out these audio signals. The range of this button can be set to values of 4.44, 4.64, 4.84, 5.25 MHz to compensate for audio channels in NTSC signals and values of 5.5, 5.75, 6.0 and 6.5 MHz for PAL.

④ RED and BLUE Color Controls

These controls allow adjustment of output levels of the Red, Blue, and Green channels by directly adjusting the Red and Blue component levels.

Red Gain

Adjusts the contrast of the Red component of the video signal. Acceptable values are from 0-63.

Red DC

Adjusts the brightness of the Red component of the video signal. Acceptable values are from 0-63.

Blue Gain

Adjusts the contrast of the Blue component of the video signal. Acceptable values are from 0-63.

Blue DC

Adjusts the brightness of the Blue component of the video signal. Acceptable values are from 0-63.

Changes in the Green level can be accomplished through the combination of the overall Gain and Brightness controls and micro-adjustments to Red and Blue. In other words, by adjusting Red and Blue values down, you can enhance the green.

Advanced Panel 3 - 3: RGB/YUV

This panel allows the output video signal standard of the G-Lock DB23 RGB output connector to be determined. Also the control of output RGB components, or the YUV color bias control is possible. If YUV is selected the only valid output is the RGB connector. The Composite and Y/C outputs will not provide an output signal suitable for those standards. Figure 6.3 shows the Advanced 3 panel. If the GL control program is active, the keyboard combination Right-Amiga-3 calls this panel into control.

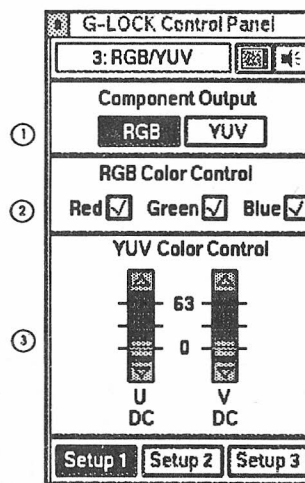

Figure 6.3 – RGB/YUV Control Panel

The Hide button, Status Line, Video and Audio Panel buttons, and the three Setup buttons are identical in operation to the Video Panel. Please refer to that section for detailed explanation.

① **Component Output RGB or YUV**

Selecting RGB will activate the RGB Color Control switches and generate RGB values at G-Lock's RGB/YUV connector. Refer to Chapter 7, Special Features, for an explanation of the use of these controls with slow-scan digitizers. Selecting YUV will activate the YUV Color Control B-Y (U) and R-Y (V) DC Bias controls and generate YUV values at G-Lock's RGB/YUV connector. As these slides are adjusted, the status window at the top of the panel will indicate the current value of the slider, the factory setting and the last saved user settings.

② **RED, BLUE and GREEN buttons**

These controls are active only in RGB mode. Clicking in any of the three RGB color boxes will turn off that color. A check mark indicates the on state of this control. Note that turning off all colors will blacken the screen making further menu selections difficult. If this happens simply hit the HELP key before doing anything else and you will be returned to the Video Panel with all colors turned on.

③ **V/U**

Adjusting either slider changes the DC bias component value of the R-Y (V) and B-Y (U) components in YUV output mode.

Note: When operating in the YUV mode, the video panel's brightness slider only affects the Y output. The Advanced 2 panel's red gain slider becomes V gain and the blue gain slider becomes U gain. The video panel's saturation slider also now only affects the U and V outputs. It must also be noted that there is no sync on the Y output but separate sync and composite sync are available on the RGB/YUV DB23 connector.

Advanced Panel 4 - 4: ECS or AA Control

This panel is only available on Amigas equipped with both the ECS Agnus and ECS Denise or AA chipset. If available this panel will allow the substitution of the key color (*normally palette color zero*) with a key color or colors determined by either Bitplane Keying or Chroma Keying selection.

To use the effects made possible through this panel, an ILBM file must first be loaded using the G-Lock ILBM Loader. After a file is loaded, double-clicking anywhere on the image will return the ECS Panel. Adjustments now made by means of the ECS panel will affect the ILBM file when it is recalled. Do this by double-clicking outside the control panel screen or using the Alt-F2 keys. To fully utilize this panel, a certain understanding of how the Amiga generates its video display is necessary. However, through experimentation anyone will be able to produce interesting and unusual keying effects.

Figure 6.4 shows the Advanced 4 panels. If the GL control program is active, the keyboard combination Right-Amiga-4 calls this panel into control.

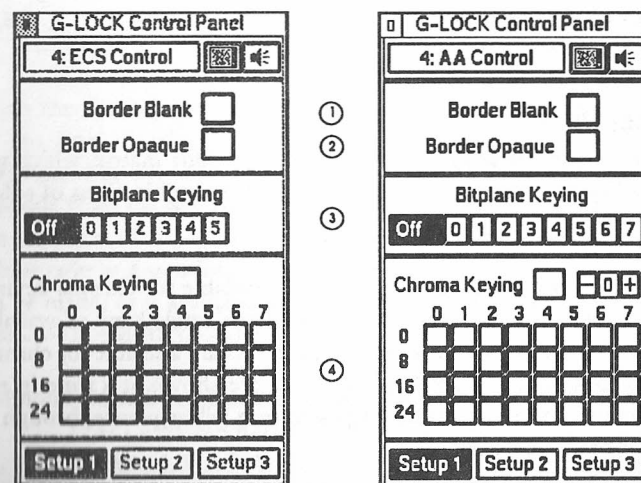

Figure 6.4 - ECS and AA Control Panels

Scanned by John



The hide button, Video and Audio Panel buttons, and the three Setup buttons function as are described previously (refer to Video Panel section).

① **Border Blank**

Any visible borders of an ILBM file are normally blanked by G-Lock to allow the genlocked signal to be completely viewed. Selecting this option (*checkmarked box*) turns off border blanking, allowing the ILBM's normal borders, if any, to mask the genlocked signal.

② **Border Opaque**

Normally off, selecting this option forces a visible border over the loaded ILBM file.

Note that Border Blank has a higher "priority" than Border Opaque, so it will be the overriding effect if both options are selected.

③ **Bitplane Keying**

Selecting this button will enable bitplane keying and activates the buttons that determine the bitplane to be used for keying. (*ie: Bitplane 0, 1, 2, 3, 4, or 5 for ECS-based machines, or 0, 1, 2, 3, 4, 5, 6, or 7 for AA-based machines.*)

④ **Chroma Keying**

Selecting Chroma keying activates the color value matrix, which will then allow the selection of any single color or combinations of colors for the keying color(s).

On ECS-based machines, 32 colors are available for chroma keying, and are represented on this control panel as a single bank of available registers. On AA-based machines, 256 colors are available for chroma keying, but only one bank of 32 colors are shown at a time in the color matrix. Clicking on the paging button will sequence through all banks of color registers.

NOTE: Bitplane Keying and Chroma Keying are intended for mutually exclusive use.

CHAPTER 7.

SPECIAL FEATURES

Electronic Color Splitter Capability

With G-Lock connected and initialized, run the Digi-View or other digitizer software as normally directed by the manufacturer. Select Digi-View's Slow-Scan/Color Camera option for the best quality images. Before the digitizing procedure begins, move back to G-Lock's Advanced 3 panel and select a color to digitize – let's start with Red. Now go back to the digitizer software and command it to digitize Red, then use Alt-F6 to switch to External mode. Repeat the process for Blue, then Green, and the process is complete.

If your digitizer software can be controlled by ARExx, it is possible to completely automate the digitizing process using an ARExx script. A sample ARExx script for use with Digi-View software (*v4.0*) is provided on disk and described in the ARExx section of this manual. To execute this script type the following at a CLI prompt and hit return:

```
RX Digi-View.REXX (The ARExx Digitizer Script)
```

Using the G-Lock composite output will produce acceptable results for the final digitized image. However, superior results can be obtained with any slow-scan digitizer if the Y (*Luminance*) signal, available from the S-VHS OUT connector, is used. A special cable, not supplied with G-Lock, is necessary in order to use the signal. (*Please refer to Appendix A for cable pin-out data.*) This custom cable can be made, or is available from Redmond Cable. The part number is RCA681, 4MMINI-2RCA.

Redmond Cable is reachable at the following address:

17371 - A1 NE 67th Ct.

Redmond, WA 98052

Phone #: (206) 882-2009

FAX #: (206) 883-1430

Scanned by John



Using a NTSC G-Lock In PAL Mode

The ability to force an NTSC G-Lock into PAL output mode, or vice versa, is possible on Amigas equipped with the ECS chip set and AmigaDOS 2.0.

Starting only from a cold boot-up on an NTSC Amiga, run ScreenMode from Preferences, select a PAL interlaced mode, and switch the Amiga to it by selecting Save. Run the G-Lock GL control program and initialize the genlock in the normal manner.

When the Amiga reboots it will come up in PAL interlaced mode and the genlock's output will be PAL. For PAL machines duplicate the process, only select a NTSC interlaced mode. If the quality of the output video is noticeably reduced, use the control panels to adjust the video.

During the automatic rebooting to genlock mode it is not unusual to experience instability of the Amiga screen. Once G-Lock loads and reestablishes system sync to the new video mode, the screen output will again become steady.

NOTE: Each G-Lock is built to give the optimum output quality for the country in which it was sold. While most video parameters are adjustable via software, specific internal components are used in its construction that optimize the genlock for that country's video standard. Therefore, the best possible output will always be produced from a G-Lock designed for that country's video standard.

De-Interlacer Operation And Compatibility

G-Lock is also designed to work with Amigas that have de-interlacer enhanced graphics. When the Amiga is running with G-Lock initialized the de-interlacer's output might at times become unstable if your video input is from a VCR. This is because the Amiga bases its video sync upon the incoming video signal, so if its quality is poor or weak the Amiga display will jitter (*although the combined genlock output will be rock solid*). Be sure the horizontal timebase control in the Advanced 1 control panel is set to VCR (*the factory default*). If the de-interlaced image is jittering and the Amiga graphics jitter, the cause might simply be mis-aligned video tracking on the VCR.

If the de-interlaced image jitters but the Amiga images are solid, try adjusting the de-interlacer fine tuning control as defined by the manufacturers setup reference manual. Usually providing the best possible input signal will result in little or no instability on the de-interlaced monitor. If nothing mentioned eliminates or diminishes the problem, your de-interlacer may not be totally compatible with G-Lock.



Chapter 8.

Questions and Answers

Q. Can I connect more than one monitor to my G-Lock?

A. Because of G-Lock's transcoding capability it is possible to simultaneously use all the available outputs for monitoring and recording.

Q. Can I switch my PAL G-Lock to NTSC, or NTSC G-Lock to PAL and still have a good output?

A. Because these two video standards are quite different and it is not easy to convert one device to the other, each G-Lock is optimized and calibrated for either NTSC or PAL output. However, it is still possible to obtain quite acceptable results when a NTSC G-Lock is run in PAL mode and vice versa. See Chapter 7.

Q. Why is the picture quality of my S-VHS (Y/C) source so poor?

A. Possibly there is a composite source connected to G-Lock. All composite sources must be disconnected from G-Lock when using a S-VHS (or Hi-8 or S-Video) source.

Q. Should I always leave G-Lock connected to a video source?

A. Yes. Even when not overlaying graphics the highest quality output from the genlock output is realized when a stable video source or external sync is available to G-Lock.

Q. What special video effects can be created with G-Lock?

A. With six possible video control panels, G-Lock can generate a wide range of special and customized effect. Here are just a few possibilities.

- Use the video and color sliders on the Video Panel to create unusual colorization of images or video.

- Easily turn a video image into black and white by selecting the Colorkill option from the Advanced 1 Panel.

- Create color-filter and colorization effects by turning on and off various combinations of RGB by using Advanced 3 Panel's RGB switches.

- Use the Advanced 4 Panel to generate unusual keying effects by experimenting with Bitplane or Chroma Keying.

Q. What special audio effects can be created with G-Lock?

A. Because G-Lock's Audio Panel allows control of the volume, bass, treble, and mute many interesting and useful effects are possible. A few are listed below.

- Use the two switchable input sources on the Audio Panel to record or create bi-lingual segments.

- Feed the left and right stereo channels into Audio 1 and 2, then select Mix 1+2 to combine the channels without the need of a "Y" cable.

- It is possible to fade in and out between available sources. While this is easily accomplished by manually manipulating the volume control sliders and audio source buttons, it is a relatively simple matter to write an ARexx script to do this automatically. See the provided Video fader script (*Fade.Rexx*) as an example of a video fade under ARexx control that could be easily modified to provide an audio fade.

- Use the treble and bass controls to preform equalization effects on the audio sources.

Q. What other programs can I use with G-Lock?

A. Any software that has an ARexx port and can multitask with G-Lock can be used.



- Q. I quit G-Lock but my Amiga is still in interlace mode?
- A. To stop genlocking and return to a non-genlocking screen mode will require either running Bypass GL or a cold-boot of the Amiga. (*Please refer to Chapter 2 for a description of these procedures.*)
- Q. When adjusting slider controls I see streaks across the screen, is this correct?
- A. Yes. However, the streaks can be eliminated or greatly reduced by using either ToolTypes or CLI parameters to set GL's priority to 21. (*Before doing this, refer to Appendix D for more information.*)
- Q. How can I convert SECAM composite (or Y/C) video to PAL video?
- A. Simply connect the SECAM inputs and the G-Lock can automatically convert this to PAL composite, Y/C and RGB/YUV output.

CHAPTER 9.

GLOSSARY

Bitplane Keying - Uses a bitplane mask to impose computer graphics onto an external video signal. *See Keying.*

Chroma Keying - Uses a fixed color value(s) for the method of imposing computer graphics onto an external video signal. *See Keying.*

Chrominance - That portion of a video signal that carries information on the color content of the image. Chrominance is encoded into a Composite signal, but is maintained as a separate channel in S-Video (Y/C) signals.

Color Zero - The first color in the Amiga color palette used to key computer graphics onto an external video source. This is the Amiga default method for determining the key. The palette color can be defined as any single color within the Amiga's currently selected color range.

Component video *See Y/R-Y/B-Y.*

Composite video - A single video signal that contains all the information necessary to form a complete image on a video display or recording machine. A Composite signal contains a sync pulse, a color burst, and modulated Luminance and Chrominance subcarriers. It may also have one or more audio channels encoded as well if it were broadcast.

Digitize - A process of converting real-world artifacts (*in this case, video pictures*) into a form recognizable and usable by a computer. Digitizing involves sampling the source material and assigning numerical values to describe it in as much detail as possible.



Encoder - A component of video systems that receives picture information and ties it to the regular frequencies of a clock oscillator. The intervals between ticks of the clock describe the pulse points for an electronic waveform that can be recorded or transmitted via radio waves. The encoder capability of G-Lock combines the separate Red, Green, and Blue video streams, along with the common time-base's sync signal, into a single channel. This signal is delivered simultaneously as Composite and Y/C (*S-VHS*) to monitors or recording devices.

Flicker - Flicker is the effect caused by the perceptible fading of video screen phosphors on alternating lines of an interlaced frame. Flicker can be remedied by either increasing the frequency of scanning or by using a long-persistence monitor whose phosphor dots do not fade as rapidly.

Genlock - Genlock is a television term meaning "generator lock." When different video signals of the same standard are *Genlocked*, their vertical, horizontal and subcarrier signals are synchronized either exactly or with a fixed offset. The second video signal is locked to the original by a digital or analog phase-locked loop.

Hi-8 - A high quality composite and Y/C format that provides superior color fidelity and resolution to the consumer market. This is the ideal format to use with G-Lock.

Interlace - Interlace is the process by which conventional video technology achieves a persistent image on a monitor screen. At low scanning rates (*15 kHz*), the screen phosphors begin to fade before the electron beam that provides the image has fully traced out a single full screen. Interlace was developed to address this problem by dividing the screen into two fields of alternating scan lines (*even and odd*). In an initial sweep of the electron beam, all of the even lines are scanned. Then, the beam returns to the top of the screen and interlaces the odd lines before the first even ones have had sufficient time to fade.

Luminance - That portion of a video signal that contains information on the relative brightness content of the image. The Luminance channel of any video signal is the primary waveform encoded on the carrier signal. Traditional Black and White television uses only a Luminance channel. Color Composite video encodes a separate Chrominance channel into the Luminance channel. In Y/C and Y/R-Y/B-Y video signals, the Luminance signal (γ) is maintained as a separate channel.

Multi-sync - A monitor capable of decoding and displaying information across a range of scanning frequencies is called, in general parlance, a multi-sync or multi-scan monitor.

NTSC - The raster scanning system used mostly in North America and Japan. NTSC has a field rate of 60Hz and 525 horizontal lines and uses a straight phase- and amplitude-modulation system for chroma. The sub-carrier frequency is 3.58MHz.

PAL - The raster scanning system used mostly in Europe and Australia. Pal has a field rate of 50Hz and 625 horizontal lines and uses a straight phase- and amplitude-modulation system for chroma, but its V color phase vector is switched 180 degrees on alternate scan lines. The sub-carrier (*phase alternate line*) frequency is 4.43MHz.

Pixel - Abbreviation for PICTURE Element, the smallest discrete unit of a video display that can be individually controlled. Video resolution is determined by the number of horizontal and vertical pixels that make up a display.

RGB - Unlike Composite, S-Video or component video systems, computers normally use a color imaging model based on discrete channels of Red, Green and Blue light. These colors, when combined at full intensity, create white light. RGB provides the most flexible means for a digital system to represent virtually any color in the spectrum in terms of the absolute amounts of Red, Green and Blue light the color contains.



SECAM - The raster scanning system used mostly in France. SECAM has a field rate of 50Hz and 625 horizontal lines but uses alternating lines of U, V chroma information to modulate the color carrier.

S-Video - A comparatively recent development in consumer video products, S-Video (*or Super Video*), achieves significantly improved performance over standard Composite encoding methods by preserving separate Chrominance and Luminance signals. See *Y/U/V*.

Splitter - Inside a video camera, picture information is detected as separate Red, Green, and Blue light sources. These signals are encoded together in a clock-driven electronic waveform for transfer to tape or broadcast. To be accessible to slow-scan digitizers, such as the NewTek Digi-View, this encoded signal must be restored to its original Red, Green and Blue signal components. This task can be performed by using G-Lock as a color splitter. See *Chapter 7*.

Standards Conversion - Conversion of one signal standard (*NTSC, PAL, SECAM*) to another, such as the G-Lock conversion of SECAM to PAL.

Sync - A sync pulse is the first event in a video signal and is used to synchronize the display device (*and any other video equipment such as alternate video sources, keying devices, etc.*). Sync signals may be present as separate Horizontal and Vertical sync signals or as a combined, Composite sync signal.

Transcoder - The ability to convert one video signal format into another signal format. Such as converting composite video into the Y/C format.

VCR - Abbreviation for Video Cassette Recorder. Referring to home-type video devices.

VTR - Abbreviation for Video Tape Recorder. Referring to high-end studio video decks.

Y/C - Abbreviation for Luminance and Chrominance, respectively; the two-channel video signal standard employed for so-called Super Video or S-Video equipment. The Luminance channel carries information on the relative brightness levels within the video frame. The Chrominance channel carries information describing the actual color content.

Y/R-Y/B-Y - Abbreviation for Luminance, Red minus Luminance, and Blue minus Luminance, respectively; the three channel video signal standard employed by so-called component video equipment. Also called *Y/U/V*, component systems derive far greater color fidelity than Composite or Y/C systems by reserving separate channels for the Red and Blue color information within the frame. Economy of bandwidth is achieved by first subtracting the relative Luminance values from the color signal (*Red value minus the Luminance value; Blue value minus the Luminance value*) and by subtracting the Red and Blue values from the overall Luminance channel to determine a value for the Green component.

Y/U/V (also YUV) - YUV refers to a color difference method that is used as an alternative to RGB for defining colors in television applications. YUV corresponds to luminance (*Y*), and the two chrominance vectors B-Y (*U*) and R-Y (*V*). RGB color space wastes valuable bandwidth in transmission. Color difference signals, using the YUV method, can be encoded and transmitted at one quarter of the bandwidth of luminance signals, saving fifty percent over RGB requirements. This allows an increase in resolution and color fidelity, making YUV the preferred method for television applications.



APPENDIX A .

TECHNICAL REFERENCE

In this appendix connector pinouts are given, the procedure for manual calibration of the G-Lock genlock is provided, and the G-Lock technical specifications are listed. This information is intended primarily as a reference for video and software engineers.

Technical Specifications

Video Inputs

CVBS1_In @ 1Vp-p/75 ohm, RCA Jack

CVBS2_In @ 1Vp-p/75 ohm, RCA Jack

-or-

Y/C_In: Y @ 1Vp-p/75 ohm ; C (*Burst*) @ 286mVp-p/75 ohm,
Mini-DIN

Minidin pin-out data:

Pin	Signal Name
Pin 1	YGND
Pin 2	CGND
Pin 3	Y Signal
Pin 4	C Signal

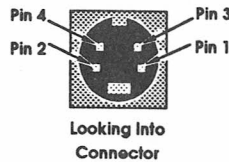

Video outputs

CVBS_Out @ 1Vp-p/75 ohm, RCA Jack

Y/C_Out: Y @ 1Vp-p/75 ohm ; C (*Burst*) @ 286mVp-p/75 ohm,
Mini-DIN (*Pinout same as input connector*)

Component Input/Output

Amiga_RGB_In @ 700mVp-p/75 ohm, DB23 on Cable (*TO AMIGA*)

RGB_Out@700mVp-p/75 ohm (*w/Separate Sync*), DB23 Out (*TO RGB MONITOR*)

-or-

YUV_OUT: Y@1Vp-p/75 ohm, UV@700mVp-p/75 ohm
(*w/Separate Sync*), DB 23 out (*TO RGB MONITOR*)

RGB Monitor Pinout Data

Pinout	DB23	Signal Name
Pin 1	-	
Pin 2	-	
Pin 3	R OUT (<i>V OUT</i>)	
Pin 4	G OUT (<i>Y OUT</i>)	
Pin 5	B OUT (<i>U OUT</i>)	
Pin 6	-	
Pin 7	-	
Pin 8	-	
Pin 9	-	
Pin 10	ACSYNC	Composite sync (<i>TTL</i>)
Pin 11	HSYNC	Horizontal sync (<i>TTL</i>)
Pin 12	VSYNC	Vertical Sync (<i>TTL</i>)
Pin 13	GROUND LINE	
Pin 14	-	
Pin 15	_VC1 (<i>3.5MHz Amiga clock, TTL level</i>)	
Pin 16	GROUND LINE	
Pin 17	GROUND LINE	
Pin 18	GROUND LINE	
Pin 19	GROUND LINE	
Pin 20	GROUND LINE	
Pin 21	-	
Pin 22	-	
Pin 23	VCC (+5VDC, <i>100mA maximum</i>)	



Sync

Composite Sync Out: TTL Level, Negative Polarity,
Pin 10 - DB23 out
Horizontal Sync Out: TTL Level, Negative Polarity,
Pin 11 - DB23 out
Vertical Sync Out: TTL Level, Negative Polarity,
Pin 12 - DB23 out

Video Performance

Video Input Standards (*user selectable*): NTSC-M, PAL-B/G/I,
SECAM-L/B/G/K

Video Output Standards: NTSC-M, PAL-B/G/I (*Amiga dependent*)

Differential Gain: >5%
Differential Phase: >5 Degrees
RGB Output Bandwidth: -3dB at 8MHz typical
CVBS (*Luma*) Bandwidth: 4.5MHz typical
Y/C Bandwidth: 5.5MHz typical
Luminance Resolution: >360 lines
Hue Control Range: +30 to -30 degrees
Minimum video in lower case burst level for color decoding: 30mV
Video (*Luma*) Peaking Range:
0db to 6db (*user selectable steps*) at 3MHz
Video (*Luma*) Delay Range:
594nS to 882nS in 6 steps (*user selectable*)
Insertion Delay (*CVBS In to CVBS Out*): 1300nS
Horizontal Lock Range: +/- 1200Hz typical
SubCarrier Lock Range: +/- 350Hz minimum
XCLK Frequency (*To Amiga*):
28.63636MHz NTSC
28.375156MHz PAL
XCLK Phase Jitter: 15nS (*Dependent on Video Input*)
CVBS1/CBVS2 Crosstalk: -35dB max
Video Trap Filter (*Color-Killer*) Attenuation: 40 dB minimum

Audio Input/Output

AUDIO1 @ Line level, 20k ohms
AUDIO2 @ Line level, 20k ohms
AUDIO_OUT @ Line level, 100 ohms

Audio Performance

Frequency Response: 20Hz to 20kHz
Programmable Volume Gain: -64dB to +6dB, 2dB steps
Programmable Bass Gain: -12dB to +15dB, 3dB steps @ 50Hz
Programmable Treble Gain: -12dB to +12dB, 3dB steps @ 15kHz
Mute Control: -80 dB when active

Power Supply

+5VDC - 150mA maximum
+12 VDC - 350mA maximum

FTZ/FCC Class B Approved



G-Lock Manual Calibration Procedure

The G-Lock genlock from Great Valley Products has been designed with the latest VLSI technology to provide our customers with the most reliable and cost effective genlock possible. To this end, the G-Lock genlock hardware has been factory calibrated for the expected video standard that the customer will use. For example, the genlocks shipped to North American markets have been factory calibrated to the NTSC standard and genlocks shipped to European markets have been factory calibrated to the PAL video standard.

It is almost always possible for the user who has the right test equipment and skills to "tweak" the software settings of the G-Lock to get even better results. For this reason, the following calibration procedure is provided so that experienced video users and/or technicians can exactly calibrate their genlock to the NTSC or PAL video standards applicable to their G-Lock genlock. Please remember that genlocks sold as PAL calibrated devices have slightly different components than the NTSC versions to achieve an output that is as close to the applicable broadcast standard as possible.

This means that it is not possible to calibrate a PAL specific genlock to operate in the NTSC mode such that the output is as good as what can be obtained from the NTSC specific genlock. In almost all applications however the output from the genlock operating in the opposite mode that it is shipped as, is very good and is perfectly acceptable for many consumer applications. The saturation level as adjusted on the Video Panel may need to be increased somewhat to help compensate for the output level difference when operating in this fashion.

Please note that when playing with the different video software adjustments that you can always return to the factory calibrated values by using the "Factory Reset" option in the G-Lock control panel menu. However, if you follow the complete alignment procedure outlined below, you may not be able to get back the original factory calibration due to your physically adjusting some of the components on the G-Lock motherboard.

CAUTION: IF YOU DO SO, YOU ARE AT YOUR OWN RISK AS TO THE QUALITY OF THE VIDEO THE GENLOCK WILL PRODUCE. GVP WILL ALSO NOT BE RESPONSIBLE FOR ANY DAMAGE OR LOSS INCURRED DUE TO USER RE-CALIBRATION OF THE INTERNAL COMPONENTS ON THE G-LOCK DEVICE. OPENING YOUR G-LOCK CASE WILL ALSO VOID YOUR WARRANTY.

Note: GVP's technical support hotline will NOT be able to help you with this complex alignment procedure. You should then ONLY proceed if you are an experienced video technician!

Adjustment Procedure (NTSC or PAL G-Locks) -

Equipment needed:

- Amiga and RGB monitor (1084S) with G-Lock genlock attached
- Several shielded 75 ohm video cables, 75 ohm BNC terminators, BNC adaptors
- NTSC and/or PAL signal generator (minimum of Full-field colorbars)
(We suggest MAGNI Signal Creator model SC-P, NTSC/PAL)
- NTSC and/or PAL waveform/vectorscope monitor
(We suggest MAGNI WV-561 waveform/vectorscope monitor, NTSC/PAL)
- 175MHz Frequency counter with 10X probe
(We suggest B&K Precision 175MHz Universal Counter Model 1823)
- Plastic 1/8 inch "tweaker" screwdriver
- Digital 3.5 digit voltmeter with probes.



Setup:

If you intend to perform the entire G-Lock calibration, you must carefully remove the top cover of the genlock's case.

Connect the G-Lock to the Amiga and then connect the Amiga RGB monitor to the genlock's RGB monitor connector.

Connect the signal generator's composite output to the waveform/vectorscope monitor (*channel B*) and then connect the loop-through output of the waveform/vectorscope monitor to the CVBS1 input of the genlock by using the various cables and adaptors. Set the generator for full-field colorbars at 75% amplitude and 75% saturation if possible. For NTSC setups, the EIA-RS189A colorbars or the SMPTE bars is acceptable. For PAL setups, the EBU colorbars is acceptable.

Connect the composite output of the genlock to the waveform/vectorscope monitor (*channel A*) by using the various cables, adaptors, and 75 ohm terminators.

Connect the frequency counter's probe to TP3 and the ground clip to TP8 and set the counter to read in MHz range, with 6 digits visible.

Connect the digital voltmeter's red probe to TP9 and the black probe to TP8, set to DC volts and 20 volt range.

Now, power-up all equipment and run the GL software that initializes the genlock and reboots the computer with the advanced menus visible (*see tooltypes*). Select CVBS1 as the input and you should now see the NTSC/PAL colorbars overlaid with the GL control panel. If not, make sure that you are in overlay mode and that all of your connections are correct and instruments powered on.

Note: You must wait for the genlock and test equipment to warmup for 5 minutes to get accurate results.

Alignment Procedure

To start the procedure, first select Setup #1 and reset the settings to the factory calibrated values by using the Factory Reset/Setup 1 menu selection.

Regulator Test

Measure the +5V regulator's output with the digital voltmeter as setup in the previous section. The voltmeter should read between 4.96VDC and 5.04VDC on the TP9 header pin. If this is not correct, then something is probably wrong with your genlock and you should return it to your dealer.

WARNING: This next adjustment will invalidate the factory calibration. It is suggested that you skip this crystal adjustment and perform the rest of the calibration procedure. If you are unable to achieve any better results than the factory calibrated values then you may assume that the crystal adjustment should be performed.

Crystal Adjustment

If this first measurement is within range then measure the 4XSubcarrier frequency at TP3 with video connected and selected on CVBS1. Only one of the following adjustments will need to be made depending on what standard your genlock was factory built for.

NTSC specific genlock adjustments

The frequency counter should read 14.3184MHz +/- 100Hz for NTSC sources. Next, disconnect the CVBS1 source so that the genlock Status indicates "No Video" and using the plastic tweaker, adjust C107 such that the frequency reads the same that it did when video was connected (14.3181MHz +/- 200Hz). Reconnect the video source to CVBS1 and continue with the software adjustments.



PAL specific genlock adjustments

The frequency counter should read 17.7344MHz +/- 100Hz for PAL sources. Next, disconnect the CVBS1 source so that the genlock Status indicates "No Video" and using the plastic tweaker, adjust C108 such that the frequency reads the same that it did when video was connected (17.7344MHz +/- 200Hz). Reconnect the video source to CVBS1 and continue with the software adjustments.

Composite Video Level Adjustment#1 —

(Waveform Monitor Mode):

With the signal generator outputting the colorbar test pattern, set the waveform/vectorscope monitor to waveform mode and set the scale to be able to see one horizontal line interval.

You should set the waveform monitor to channel B to insure the correct levels coming from your signal generator and so that you may adjust any gains or levels as needed on your waveform monitor.

Set the genlock to external mode by using the GL software control panel or Alt-F6 keys. Set the waveform monitor to channel A and observe the genlocks' composite output. Now set the brightness level so that the black bar is at 0 IRE on the graticule and then set the contrast level so that the white bar is at the 75 IRE level. The best way to do this is to select the "alternate" display mode on the waveform/vectorscope monitor and adjust the IRE levels to match.

You can adjust the controls and then switch the genlocks' keyer mode to External and check it on the waveform monitor as desired. Then adjust the saturation control to match the amplitude of the yellow bar again when in the "alternate" display mode. Note that the composite output of the genlock is delayed by about 1.2uS from the input signal and this can be seen when in the "alternate" display mode of the waveform monitor.

Composite Video Level Adjustment#2 —

(Vectorscope Monitor Mode):

Again with the signal generator outputting the colorbar test pattern, set the waveform/vectorscope monitor to vectorscope mode and set the gain control for 75% colorbars. You should set the vectorscope to channel B to insure the correct levels coming from your signal generator and so that you may adjust any gains or levels as needed on your vectorscope to put chroma dots in their target boxes.

Set the genlock to external mode by using the GL software control panel or ALT-F6 keys. Set the vectorscope to channel A and observe the genlocks' composite vector output.

Toggle back to overlay mode (*via Alt-F6*) and select the Advanced#1 menu. Adjust the saturation balance control, the subcarrier phase control, and the gain balance control to fix the chroma dots as close as possible to their respective target boxes.

You may find that the Luma Delay setting in the Advanced#2 menu will need adjustment to make the interconnected chroma lines as straight as possible and then fine tune the previous three adjustments to make the vectorscope display look as close to the signal generators output as possible.

You will find that the adjustments can best be made when the vectorscope is set to line select mode where you are viewing only a single line (*we suggest line 31*) for both NTSC and PAL modes. After you have made your adjustments you can put the genlock in External mode and view the vectorscope display for the entire frame if desired to see your final results. Recheck your composite output in the waveform mode and fine tune any of the previous controls as needed.

Now save your calibrated results to *all* setups and after this go back and set up the individual setups (1,2,3) for different video sources, audio sources, ECS modes, etc. now that all setups have the re-calibrated values as a baseline from which to modify.



APPENDIX B.

KEYBOARD SHORTCUTS AND HOT-KEYS

This is a list of all menu keyboard equivalents and Hot-keys. In all instances Amiga refers to the right-Amiga key.

Keyboard Equivalents

Amiga O	Load setting, this setup
Amiga S	Save this setup
Amiga F	Factory reset, this setup
Amiga H	Hide control panel
Amiga Q	Quit G-Lock
Amiga V	Video Panel
Amiga A	Audio Panel
Amiga 1	Advanced 1 Panel
Amiga 2	Advanced 2 Panel
Amiga 3	Advanced 3 Panel
Amiga 4	Advanced 4 Panel
Amiga L	Load ILBM
Amiga C	Close ILBM

Hot-Keys

Alt-F1	Pop up control panel
Alt-F2	Pop up ILBM screen
Alt-F3	CVBS1 input select
Alt-F4	CVBS2 input select
Alt-F5	Y/C input select
Alt-F6	Amiga/Overlay/External mode
Alt-F7	Inverse mode
Alt-F8	Audio1/ Audio2/ Mix 1+2
Alt-F9	Mute on/off
Alt-F10	Hide control panel
Alt-Help	Undo last change
Shift-Help	Reset to last saved
Alt-Help	Reset to factory

These HotKeys are reprogrammable under AmigaDOS 2.04 or later, using ToolType entries in the GL program icons.



APPENDIX C. TOOLTYPES

All ToolType names and values are, if not identical, at least equivalent to the CLI options.

ToolType	Description
LACE=ON	Always force interlace on all screens
LACE=OFF (default)	Don't interlace non-interlaced screen Turn on interlace if the Amiga is genlocked
TIMING=PAL	Forces G-LOCK to operate in PAL mode
TIMING=NTSC (default)	Forces G-LOCK to operate in NTSC Checks the Workbench screen
MODE=BYPASS (default)	Bypass the genlock entirely Genlock mode
SETUP=n (default)	Select setup n (1-3) to start up Setup 1 is the normal startup
MINBRIGHTNESS=n	Sets the lowest setting accepted to n
MAXBRIGHTNESS=n (default)	Sets n as the highest setting accepted Minimum: 0, Maximum: 63
CHECKINTERVAL=n (default)	Set number of frames (1-100000) for signal check Every 60 frames
PRIORITY=n (default)	Set program priority to n (-5<n<60) Priority 0

FORCESCREENMODE=xxx Ignore extended modes
(default) Take extended modes into account

MENUS=ADVANCED Show advanced menus
(default) Show only the standard menus

NOGUI=xxx Starts up without showing the panel
(default) Show Video/Audio Panel on start-up

ToolType names for hotkeys and their defaults are listed below.

CX_POPKEY = Alt F1	Call control panel to front.
ILBMTOFRONT = Alt F2	Call ILBM Loader or loaded ILBM file to front.
CVBS1 = Alt F3	Select video source from CVBS1.
CVBS2 = Alt F4	Select video source from CVBS2.
YC = Alt F5	Select video source from S-VHS IN.
KEYER = Alt F6	Switches between keyer modes.
INVERSE = Alt F7	Toggles Inverse mode.
ASOURCE = Alt F8	Toggles audio source and Mix 1+2.
MUTE = Alt F9	Toggles audio mute on and off.
DEACTIVATE = Alt F10	Hides control program user interface.



APPENDIX D.

CLI PARAMETERS

Below is a list of CLI keywords and arguments. Be sure to insert a space between each keyword and its argument.

Video Timing Selection

Keyword	Argument	Description
FORCEPAL	None	Forces G-LOCK to operate in PAL mode
FORCENTSC	None	Forces G-LOCK into NTSC mode

Default mode is the video-format of the Workbench screen in use.

2.0 specific: A warning is issued if the Workbench is in a screen-mode that is not genlock compatible (e.g. VGA: Productivity).

Initial Setup selection

SETUP	1-3	Starts G-Lock software in specific setup
-------	-----	------------------------------------------

The default setup is Setup 1.

Brightness settings limits

MINBRIGHTNESS	0-63	Sets the lowest setting accepted
MAXBRIGHTNESS	0-63	Sets the highest accepted level

Default Min/Max levels are 20 to 45.

To avoid problems with the picture level being mistaken for the sync signal (applies to composite output only), minimum level can be set. The default minimum level is zero.

For the sake of completeness, the maximum setting is also settable (*default: 63*). The G-Lock software verifies that the following is always true:

$0 \leq \text{Min} \leq \text{ActualSetting} \leq \text{Max} \leq 63$

and that the graphic user interface is updated accordingly.

Checking Interval

Keyword	Argument	Description
CHECKINTERVAL	0-100000	Set interval for validity check

Default interval is once a second.

When the G-Lock detects a video signal present in the input connector, it periodically checks to ensure that this signal is still connected. This setting describes the interval in number of frames (*50 per second in PAL, 60 per second in NTSC*).

A setting of zero frames will disable the checking - this is useful for people who have a stable video source connected at all times.

The "Continuous Signal Check" menu-item in the Extras menu allows the user to toggle between a setting 0 (*no checking*) and 60/50 (*once a second*), or the value set by this ToolType.

Task Scheduling Priority

PRIORITY	-5 to 60	Set program priority
----------	----------	----------------------

Default priority is 0.

Because of the critical timing involved in data transfer between the Amiga and the G-Lock's video circuitry, a high task priority is an advantage if flicker free video adjustment is necessary.

Setting the priority to 21 or above improves the chances of smooth adjustment, as this gives the G-Lock control panel a higher priority than input.device which runs most of Intuition's activities. On a slow machine (*e.g. one without Fast Ram*), the cost of this is a more sluggish screen update when controls are adjusted.

This higher priority may cause data loss during serial transfers at baud rates greater than 9600 bps. To avoid these problems, set GL's priority to 0 and place it in Hide mode or refrain from making adjustments to GL's sliders during serial transfers. Users of serial cards, such as GVP's I/O Extender will not experience any problems.



G-LOCK Operational Mode

BYPASS	None	Set mode to bypass
NORESETREQUEST	None	Reboots silently, if needed

Default mode is GENLOCK, and reboots With requestor.

This option is useful if the Amiga is to run unattended, for example in a kiosk or if the user runs the program from *s:user-startup*.

Menus

ADVANCED	None	Advanced Mode <i>(all possible menus)</i>
None	None	Standard Mode <i>(only Video/Audio Panel)</i>

Default is unspecified (*Standard mode*).

This option allows all possible advanced panels of G-Lock to be accessed.

Silent Startup

NOGUI	None	Starts up with no panels
-------	------	--------------------------

Default is unspecified (*GUI enabled*).

With this option the Video Panel is not shown upon program startup. The ARexx port and the Hot-keys are active, however.

Setting the system-wide interlace bit

LACEON	None	Interlace all screens
LACEOFF	None	Interlace only interlaced screens

The default operation is to check whether or not the Amiga is genlocked to an external sync source, and if so, force interlace on all screens.

Forcing all ILBM screens to be in a specific screen-mode

FORCESCREENMODE	None	Even 32 bit ILBMs are coerced
-----------------	------	-------------------------------

Default takes extended modes into account for AmigaDOS version greater than 2.04.

Usually extended mode ILBM screenmode are shown in their extended mode. Since that might interfere if the Amiga is genlocked, this option offers to force ILBMs to be shown in NTSC or PAL, depending upon selected configuration.

Scanned by John



APPENDIX E.

AREXX AND AMIGAVISION REFERENCE

A number of ARExx scripts and an AmigaVision flow are provided with G-Lock to demonstrate some advanced special effects that are possible under ARExx or AmigaVision control. The examples provided are only intended to give you a start in the using G-Lock with ARExx or AmigaVision. Examine each script with a text editor, then expand and customized them to meet you production needs. The function of each script and flow are described below. Also included is a special G-Lock shell that can be opened to allow ARExx commands to be entered directly from the keyboard. The ARExx command set is included at the end of this appendix.

Fade.REXX

This ARExx script enables G-Lock to preform a simple A/B roll between two video sources.

Digi-View.REXX

This ARExx script enables G-Lock to be used with NewTek's Digi-View software. Run the Digi-View and G-Lock software, then run this script.

Shell.GL

This is a special CLI/Shell that will allow all G-Lock ARExx commands to be entered via the keyboard. This will allow complete control of most of G-Lock's controls and features.

AmigaVision Flow

A sample AmigaVision flow script is provided for use with G-Lock.

ARExx Commands

Below is a list of ARExx commands, and return strings.

Command	Argument/Return Strings
BRIGHTNESS	0-63
CONTRAST	0-63
HUE	0-63
SATURATION	0-63
VSOURCE	CVBS1, CVBS2, or Y/C
KEYER	EXTERN, AMIGA, OVERLAY, or INVERSE
MUTE	ON or OFF
ASOURCE	AUDIO1, AUDIO2, or MIX

Command	Argument	dB Equivalent
VOLUME	0	-64
	1	-42
	2	-20
	3	-18
	4	-16
	5	-14
	6	-12
	7	-10
	8	-8
	9	-6
	10	-4
	11	-2
	12	0
	13	+2
	14	+4
15	+6	
BASS	0	-12
	1	-9
	2	-6
	3	-3
	4	0
	5	+3
	6	+6
	7	+9
	8	+12
9	+15	

Scanned by John



TREBLE	0	-12
	1	-9
	2	-6
	3	-3
	4	0
	5	+3
	6	+6
	7	+9
	8	+12

Command	Argument
COLORMODE	PAL, SECAM or AUTO
COLORKILL	ON or OFF
SUBCARRIERPHASE	0-63
BYRYGAINBALANCE	0-63
SATURATIONBALANCE	-63
HSWITCH	CAMERA or VCR
LUMAPEAKING	0.0, 1.0, 2.0, 2.9, 3.6, 4.2, 4.8, or 5.4
LUMADELAY	594, 650, 706, 762, 818, or 882
FILTERTRAP	5.5, 5.75, 6.0, 6.5, 4.44, 4.64, 4.84, or 5.25
BLUEGAIN	0-63
BLUEDC	0-63
REDGAIN	0-63
REDDC	0-63
ADJUSTAMIRGB	ON or OFF
COMPONENTOUT	YUV or RGB
RGBOUT	ON or OFF
ROUT	ON or OFF
GOUT	ON or OFF
BOUT	ON or OFF
UDC	0-63
VDC	0-63

The following ARexx commands are used to set the user's environment.

SAMPLEPERIOD	0-100000
SETUP	1-3
MENU	VIDEO, AUDIO, ADVANCED 1-4

The following Arexx commands act as commands, not controls. Unless specified, they have no arguments..

WAITFRAME	
LOAD	
SAVE	
FACTORY	
ACTIVATE	
DEACTIVATE	
PANELTOFRONT	
PANELTOBACK	
QUIT	
LOADILBM	file name
ILBMTOFRONT	
ILBMTOBACK	
UNLOADILBM	
STATUS	Returns video status line

The following controls are only operational with an ECS or AA chipset equipped Amiga.

BORDERBLANK	ON or OFF
BORDEROPAQUE	ON or OFF
CHROMAKEY	ON or OFF
BITPLANEKEY	OFF, 0, 1, 2, 3, 4, 5, 6, or 7
CHROMA0 - CHROMA31	ON or OFF (ECS Chipset)
CHROMA33 - CHROMA255	ON or OFF (AA Chipset)

NOTE: For those commands that have arguments, giving the argument "factory" will reset that parameter to the factory set value.

Scanned by John



APPENDIX F.

CUSTOMER SERVICE

GVP provides customer support for its hardware and software products through its network of authorized dealers. In most cases, your dealer may offer the fastest and most convenient solution when repair or replacement of equipment is necessary.

GVP also maintains a telephone Technical Support line, Monday, Wednesday, Thursday, and Friday, from 9:15 a.m. to 6:00 p.m. Eastern Time in the United States at (215) 354-9495. On Tuesdays, the Tech Support line opens at 10:30 a.m. Wherever possible, callers should determine that the problem they are reporting is repeatable (*i.e.: it happens more than once*), and be able to describe in detail the particular symptoms and system configuration in use.

GVP can also be reached via FAX, at (215) 337-9922 or by post at our U.S. mailing address:

Great Valley Products, Inc.
600 Clark Ave.
King of Prussia, PA 19406

Customer Number: _____

APPENDIX G.

PROBLEM REPORTING FORM

When calling GVP Customer Service, please take the time to complete this form. Telephone support personnel will be better able to assist you if you can provide this detailed information. Users may, alternately, FAX a copy of this form to GVP at (215) 337-9922.

Name: _____

Date: _____ Cust. Number _____

Address: _____

City: _____ State: _____

Country: _____ Postal Code: _____

Telephone Number: _____

Product: _____

Serial Number: _____

Revision: _____

Describe the problem in terms of symptoms and the conditions under which it occurs: _____

Scanned by John



Machine Configuration

Amiga Model: _____

Motherboard Revision: _____

Kickstart (ROM) Version: _____

Workbench Version: _____

Chip Set Version: _____

Amiga CPU installed: _____

Amiga clock speed: _____

Hard Drives Attached:

List the Unit ID numbers, manufacturers and capacities of all hard drives attached to your system; also any floppy, tape or other devices:

INDEX

9 pin cable 17

A

AA Control 43

Advanced

Control Panels ... 35

Menu 26

Mode 20

Amiga Keyer Mode 32

Amiga RGB Saturation .. 39

ARexx Commands 75

Audio

1 18

2 18

Button 30

Connections 18

Control Sliders .. 34

Input 7

Input/Output ... 59

Out 18

Output 7

Panel 33

Performance 59

Source 34

B

Basic Configuration 5

Bass Control Slider 34

Bitplane Keying 44

Blue

Button 42

Color Controls ... 40

DC 40

Gain 40

Border Blank 44

Border Opaque 44

Brightness Slider 31

BypassGL 10

C

Chroma Keying 44

CLI Parameters 70

Close ILBM Screen 28

Color Selection 37

Color Splitter 44

Component Input/Output . 57

Component Output 42

Composite Input 7

Composite Output 7

Connecting G-Lock 6

Connections 16

Continuous Signal Check . 27

Contrast Slider 31

Control Program 20

CVBS 1 7, 17, 32

CVBS 2 17, 32

CVBS Out 7, 18

Scanned by John



D
De-Interlacer Compatibility . 47

E
ECS Control 43
Electronic Color Splitter . 44
External Keyer Mode 32
Extras 27

F
Factory Reset 23
Filter Trap 39

G
Gain Balance 37
GL 20
Green Button 42

H
Hide 24
Horizontal Timebase 37
Hot-Keys 24, 67
Hue Slider 31

I
Initializing G-Lock 8
Installing Software 8
Interfaces 16
Inverse Keyer Mode 32

K
Keyboard Equivalents 66
Keyer Mode 32
Kill Color 37

L
Load ILBM 28
Load Settings 22
Luma Delay 39
Luma Peaking 39

M
Manual Calibration 60
Menus 21
Multiple video inputs 17
Mute 34

N
NTSC in PAL mode 46

O
Overlay Keyer Mode 32

P
PAL 36
Project 21

Q
Quitting G-Lock 9, 26

R
Red
Button 42
Color Controls . . . 40
DC 40
Gain 40
RGB
Interface 16
Monitor 19
Monitor Pinout . . 57
Output 42

S
S-VHS
In 17
Out 18
Output 7
Saturation Balance 37
Saturation Slider 31
Save 22
SECAM 36
Setup 20
Signal 31
Slider Value Indicator . . 30
Standard
Menu 26
mode 20, 21
Status Indicator 30
Subcarrier Phase 37

T
Tool-Types 68
Treble Control Slider . . 34

V
V/U 42
Video
Button 30
Control Sliders . . . 31
Input 17, 32, 56
Outputs 18, 56
Panel 29
Performance 58
Tuning Sliders . . . 37
Volume Control Slider . 34

Y
Y/C Input 32
YUV Output 42

